



ROYAL NOVA

Office Furniture



United Arab Emirates

Suite 26C-09, I-Rise Tower, Barsha Heights (Tecom), Hessa St., Dubai

Tel.: +971 4 390 8325 email: info@royalnova.com <http://www.royalnova.com>



ABOUT US

Royal Nova is a renowned brand in the global market for home, office and outdoor furniture, lighting and interior furnishings. We prioritize product realization, harmony, style and modern living, continuously adapting our image and functionality to meet customer preferences. Our strong presence extends to domestic and international markets, with a specific focus on exports. By recognizing that true innovation comes from experience, Royal Nova has established itself as a dependable and visionary brand known for conceptualizing ground breaking solutions. Our diverse collections cater to a wide range of customers, offering prompt delivery nationally and internationally.

Royal Nova is synonymous with timeless designs that embody contemporary style. Our furnishings provide beautiful and comfortable options for homes and offices, combining style, quality and comfort seamlessly.

To achieve excellence, Royal Nova has forged joint venture collaborations with top manufacturers in China, Singapore, Malaysia and Europe. These collaborations enrich our passion, talent and skill with cutting-edge technologies, advanced production methods, high-quality materials, and sophisticated stylistic research. As a result, our products adorn exclusive and elegant homes and offices worldwide.

Royal Nova's partners are the industry leaders, constantly develop new products that reflect our commitment to design and innovation through ongoing research and development. By working closely with clients, we anticipate and fulfill their requirements, ensuring a consistent supply and strict compliance with international environmental standards.

In summary, Royal Nova is a reputable and reliable brand renowned for its contemporary designs that seamlessly blend style, quality and comfort in the world of furniture and lighting.

CREATIVITY AND
DESIGN, STYLE CAN
REFLECT YOUR
PERSONALITY AND
TASTE



ART OFFICE "

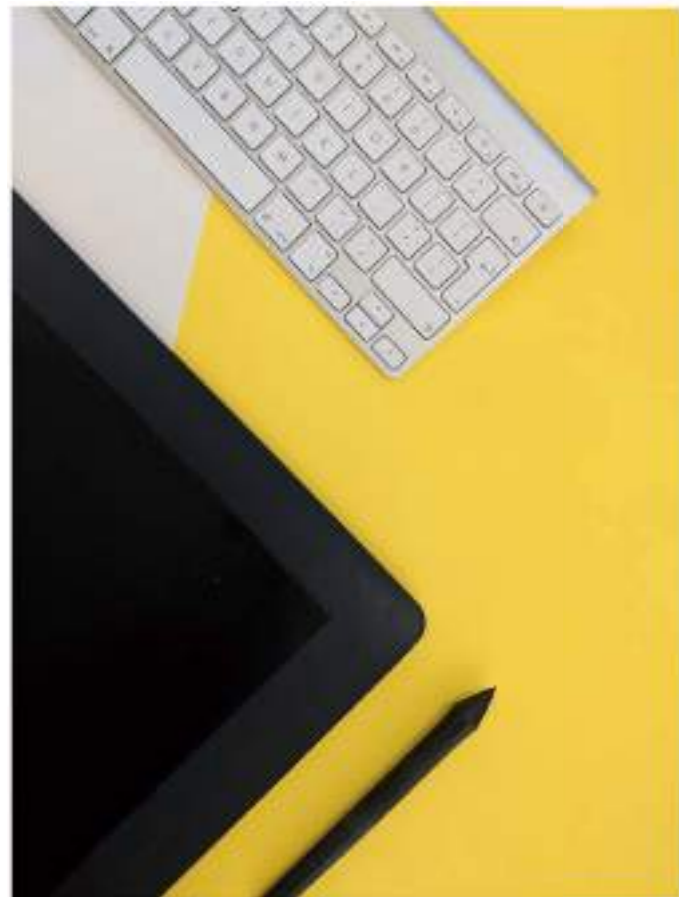

fashion

Unusual vision gives ordinary meaning



STYLISH OFFICE SPACE

CRAFTSMANSHIP



▶ The luxury of craftsmanship_



CREATIVE DESIGN "

Originality Extreme



OPEN A NEW WORLD OF OFFICE



Fashion Office

Bold classic
creative inspiration



create the little era belonging us



Creativity comes
from thinking

MORE THAN DESIGN



Original



天气生财 Wise Forward
睿智前行





DESIGN NEW CHAIR



Model: **HR-B01**



Model: **HR-A01**



Model: **HR-C01**



"FASHION"

The comfort in the heart

The people-oriented design concept advocates the perfect combination of vision and touch, and the intricate details that are difficult to detect reveal elegance and elegance.

**CREATE
EXTRAORDINARY**





DESIGN NEW CHAIR

Excellent design, enjoy the modern comfort



Model: **HR-A02**



Model: **HR-C02**

**COMBINING SCIENCE
AND ART**



Model: **HR-B02**

THE FINELY DETAILED WORK, GIVES THE NORMAL SPACE
UNCOMMON SENSE OF VISION: NEAR-SURPRISING AESTHETIC
APPEAL, GIVES THE OFFICE SPACE THE UNIQUE CHARM.







Model: **HR-A03**



**WONDERFUL
OFFICE LIFE
INCOMPARABLE**



Model: **HR-B03**



Model: **HR-C03**

"GRACEFUL"

Excellent design, enjoy the modern comfort





"MODERN"

Fashionable color blocking design, giving the space infinite vitality

ENJOYMENT OF
FUNCTIONALITY
AND ART



Model: **HR-A04**



Model: **HR-B04**



Model: **HR-C04**





"FASHION"

The comfort in the heart



Model: **HR-A05**

PERFECT
DESIGN



Model: **HR-B05**



Model: **HR-C05**

It not only creates outstanding products, but also shows the mainstream trend of contemporary design art. It uses imagination to talk with you, making you feel good and you can feel the atmosphere of the times.





DESIGN NEW CHAIR



Model: HR-C06-1



Model: HR-B06



**NOT
INTROVERTED**



Model: HR-A06-1

FOR THE PASSION FEELINGS



Model: HR-C06







ELEGANT TASTE

AS THE BOUNDARIES BETWEEN LIFE



Model: **HR-B07**



OPEN AND STYLISTIC

An ideological journey initiated by dreams has no fixed point of view and position and it can be seen as a free rein between the artistic world and real life. Maybe it's a poetic space, a fascinating chair. Here, I forget the constraint, the rules, and freely enjoy the comfortable state composed by space and human



Model: **HR-C07**

DEGREE OF
COMFORT



“LUNCH”

Good seat to get you a good nap



Model: **HR-A08**



Model: **HR-A08-1**







Model: **HR-B09**



Model: **HR-C09**



Model: **HR-A09**



“GRACEFUL”

Excellent design, enjoy the modern comfort



Model: **HR-B09**



Model: **HR-C09**



Model: **HR-A10**



Model: **HR-B10**



Model: **HR-B10**



Model: **HR-A13**



Model: **HR-B13**



Model: **HR-C13**



Model: **HR-A11**



Model: **HR-B11**



Model: **HR-C11**



Model: **HR-A14-1**



Model: **HR-A14**



Model: **HR-B14**



Model: **HR-A12**



Model: **HR-B12**



Model: **HR-C12**



Model: **HR-A15**



Model: **HR-B15**



Model: **HR-C15**



Model: **HR-A16**



Model: **HR-B16**



Model: **HR-C16**



Model: **HR-A19**



Model: **HR-B19**



Model: **HR-C19**



Model: **HR-A17**



Model: **HR-B17**



Model: **HR-C17**



Model: **HR-A20**



Model: **HR-B20**



Model: **HR-C20**



Model: **HR-A18**



Model: **HR-B18**



Model: **HR-C18**



Model: **HR-A21**



Model: **HR-B21**



Model: **HR-C21**



Model: **HR-A22**



Model: **HR-B22**



Model: **HR-C22**



Model: **HR-A25**



Model: **HR-C25**



Model: **HR-C25**



Model: **HR-A23**



Model: **HR-B23**



Model: **HR-C23**



Model: **HR-A26**



Model: **HR-B26**



Model: **HR-C26**



Model: **HR-A24**



Model: **HR-B24**



Model: **HR-C24**



Model: **HR-A27**



Model: **HR-B27**



Model: **HR-C27**



Model: **HR-A28**



Model: **HR-B28**



Model: **HR-C28**



Model: **HR-A31**



Model: **HR-B31**



Model: **HR-C31**



Model: **HR-A29**



Model: **HR-B29**



Model: **HR-C29**



Model: **HR-A32**



Model: **HR-B32**



Model: **HR-C32**



Model: **HR-A30**



Model: **HR-B30**



Model: **HR-C30**



Model: **HR-A33**



Model: **HR-B33**



Model: **HR-C33**



Model: **HR-A34-1**

NOT INTROVERTED

Focus of vision



Model: **HR-B34**



Model: **HR-A34**



Model: **HR-C34**

Taste multi-level charm

It not only creates outstanding products, but also shows the mainstream trend of contemporary design art. It uses imagination to talk with you, making you feel good and you can feel the atmosphere of the times.

DEGREE OF
COMFORT



Model: **HR-A35-1**

“FASHION”

The comfort in the heart

Regardless of the in-depth application of ergonomics or the careful selection of modern materials, they deeply reflect the craftsmanship of well-known brands and their dedication to environmental protection, just to make each product meet the international office chair standards.



Model: **HR-B35**



Model: **HR-C35**



Model: **HR-A35**

PERFECT DETAILS



Model: **HR-B36**



Model: **HR-C36**



Model: **HR-B37**

ABSOLUTE PERFECT FURNITURE





VISUAL IMPACT

Like it/
Fashion Chair



Model: **HR-B38**



Model: **HR-C38**



The creative design of the structure has been amazing, and it is worthy of your taste in the production process. From the details, you can also get the quality and taste of the product.



Model: **HR-B39**





Model: **HR-B40**



"FASHION"

The comfort in the heart



ART OF BEAUTY

Perfection is an endless pursuit. She is almost perfect. Art space sense of retractable and strong flavor of the nature around the meantime, concise and clear lines and elegant appropriate decoration which runs through. Modern office concept for the evolution of the times, with the times to give her a more powerful vitality.



Model: **HR-B41**





Model: HR-43



Model: HR-42

OPEN AND STYLISTIC



ELEGANT TASTE

AS THE BOUNDARIES BETWEEN LIFE



DEGREE OF
COMFORT

Model: **HR-45**



Leisure



Model: **HR-44**



The doctrine of simplicity is to simplify the design to its essence and emphasize its inside fascination. In this realm that interweaves modern and future, simplicity produces rationality, order and professional sense.



Model: **HR-46**



Model: **HR-47**

Fashion
design

LIFE-VOGUISH



Model: **HR-48**

NEW LEISURE CHAIR

Office Style



Model: **HR-49**

LEADING THE TREND

The music is from our heart and the environment can influence our mood. In the efficient space, we can place some simple but colorful office furniture to create the happy symphony between space and furniture. In the relaxing ambiance, the mind seems to come alive, the inspiration is continuously stimulated and the passion is overflowing. When we enjoy sitting on it and appreciate the physical and mental happiness, you may forget to get off the work.



Model: **HR-50**



The simple lines and spaciousness of the sofa make it an ideal choice for any home, office, hotel or lobby.



Model: **HR-52**

INTOXICATING COMFORT

Model: **HR-51**



The creative design of the structure has been amazing, and it is worthy of your taste in the production process. From the details, you can also get the quality and taste of the product.



Model: **HR-53**



Model: **HR-54**

Variety and versatility

Eclectic lines are smooth, inherently restrained and elegant, naturally exuding a sense of luxury, and a rich sense of fashion gives a calm and comfortable feeling



OPEN AND STYLISTIC

An ideological journey initiated by dreams has no fixed point of view and position and it can be seen as a free rein between the artistic world and real life. Maybe it's a poetic space, a fascinating chair. Here, I forget the constraint, the rules, and freely enjoy the comfortable state composed by space and human

Model: **HR-56**



Model: **HR-55**



Model: **HR-57-1**

Intoxicating Comfort



The creative design of the structure has been amazing, and it is worthy of your taste in the production process. From the details, you can also get the quality and taste of the product.



Model: **HR-57**



Model: **HR-58**



Model: **HR-60**

JUST A CHAIR,BUT IT IS MOST BEAUTIFUL

The dream may go ahead alone, but the passion will never go out. Even if there is only one chair left to accompany me, I will sit with her to create my era.



Model: **HR-59**



DISCOVERY CHANGES THE WORLD



Model: **HR-61**

THE COMBINATION

Comfort combined with aesthetics



Model: **HR-62**



Model: **HR-64**

Variety and versatility

Eclectic lines are smooth, inherently restrained and elegant, naturally exuding a sense of luxury, and a rich sense of fashion gives a calm and comfortable feeling



Model: **HR-63**



FASHION OFFICE



FASHION OFFICE

THE UNIQUE STYLE OF
MODERNISM AND SUPERIOR

**_ FREEDOM _
AND BOLDNESS**





Nobody knows where is confidence from,

maybe it has thousands of sources and millions of incarnations. But when we sit on these noble and comfortable office chairs, self-confidence is really not far away.

Breakthrough design starts a new mode of conference chair.

Unique material selection and consummate techniques create particularly beautiful and elegant atmosphere, giving you endless business inspiration to have best performance in work and to keep winning in the intense commercial competitions.

A GOOD PRODUCT, FOR ALL
TO SEE!

ELEGANT DESIGN INSPIRATION



● MD2157A-2



● MD2157B-2

Fashion, popularity is
its most brilliant and brightest expression.

Style, personality is its most unique expression. And casualty,
comfort is its most
tender and exquisite face. Steelbest swivel chair clearly
demonstrate the new view of
modern office furniture.



SHOWING THE ELEGANCE
THROUGH THE ORDINARINESS

**_GOOD FOR PEOPLE_
GREAT
FOR BUSINESS**



● MD2157A-1



It creates completely industrialized image with simple

geometric surface,neat,thoughtful,pretty and easy,tough,and with detail,just like new generation of people in workplace,who shake off all formal fetter,to seek the spiritual and creative relief,remarkable and unmatched.



● MD2157B-3



● MD2157A-3



MANDE OFFICE CHAIR

**CREATEFASHION-
ABLESPACE**

A GOOD PRODUCT, FOR ALL
TO SEE!

**ELEGANT DESIGN
INSPIRATION**



● MD2157C

everything makes people so
deep and graceful.

The respect for office furniture art of Europe
shall be generated wherever your sight is and which
Site your hand touch. It seems to enter into the
time tunnel, touch the history and one kind of
living art history of European aristocrats with body
temperature.

A GOOD PRODUCT, FOR ALL
TO SEE!

ELEGANT DESIGN INSPIRATION



● MD2157A-1H



Fashion, popularity is
its most brilliant and brightest expression.

Style, personality is its most unique expression. And casualty,
comfort is its most
tender and exquisite face. Steelbest swivel chair clearly
demonstrate the new view of
modern office furniture.

All is based on the clever collision
of traditional

craftsmanship and aesthetic concept of the modern
noble. It is meticulously made with pure natural
materials, and it is leading the trend of the times,
with epoch-making creativity.



WHERE THERE IS THOUGHT
— THERE IS —
VITAL FORCE



● MD2157A-3H



● MD2157C-1H



● MD2157B-3H

MAKE YOUR OFFICE ROUTINE
FASHIONABLE

**_ALLOWING YOU SITS_
WITH PLEASURE**



● MD2157B-5H



● MD2157C-2



● MD2157A-5H



THE UNIQUE STYLE OF
MODERNISM AND SUPERIOR

**_ FREEDOM _
AND BOLDNESS**



● MD2157A-4



● MD2157B-4



Thinker of office chair

Life Office

OFFICE *for* FASHION YOUNGER

> Fall in love with, because I sit up!

Living Office

That is more cozy feeling than staying in bed.





About The Material, About The Color

The first-class cloth material and the craftsmen spirit of the top luxury, makes each FURICCO chair product revealing the flawless process details, shining with the perfect image of high-end products.

The same office chair use different material and color can produce distinct adornment effect; this is because the material and color itself also represents a kind of beauty, that beauty is material, color itself inherent. It is only good at discovering the beauty, good at using this kind of beauty, office chair design to produce the best overall effect.



| Furniture of the fashion show

The example of the bench demonstrates an effective articulation and manipulation of the criteria for seating Nelson would lay out some 20 years later in Herman Miller's 1964 catalog. Function and purpose, human anatomy, the psychology of the occasion, and physical properties all come together to solve a particular problem—in this case, Nelson's distaste for unscheduled interruptions.



EXTREME CHARMING VISUAL FEAST



B1720-1



C1720-2

| COLOR YOUR OFFICE SPACE





B1720-1



B1720-1

Color Mixing

Select a beautiful office chair; ignite the brilliant color of office.

In the lonesome summer, I packed all young feelings with my in official document bag, and purchased my own little office, with infinite longing entrepreneurship, I wanted to know what was the best office chair?. I searched again and again, always had no obtaining. Until I saw it, it is like the tail met the magnet; the clear and fresh attractive lemon yellow was like beautiful like summer flowers, warm and bright and faintly emitted the delicateness and shy. The exquisite electroplating hardware feet was striving to stretch, extremely proved and own mature... at the end, until I was speechless, the original so-called best office chair, is the "romantic beyond the expression of the words



B1720-1

Amative Nobility

We use the bright colors to give a happy mood, with color to awaken the space vitality. The joy is accumulated in daily work and sends out.

| COLOR YOUR OFFICE SPACE



Color Mixing



C1702-2

C1702-2

B1702-1

C1702-1

B1702-1

C1702-1

B1702-2

B1702-1



COLOR RHYTHM

MAKE YOUR OFFICE BEAUTIFUL

C1702-1

With the feelings of freedom, lazily lying in a comfortable office chair, always sigh with emotion...



C1702-1

Should I go left or right?

A warm temperate, a pure and fresh and soft, standing between fine and high-quality goods, appreciate more affection and sentiment.



B1702-2



C1702-2

➤ Quiet feeling.

Sweet pink and charm purple are spread feelings to you, oh, you can or not come!



D356

F1633-3

COLOR MIXING STYLE
COLOR YOUR OFFICE SPACE

Sweet pink and charm purple are spread feelings to you, oh, you can or not come!

Sweet pink and charm purple are spread feelings to
you, oh, you can or not come!

Watermelon Red

Interpretation of fashion charm



D356



When the charm circular arc meets the puzzled straight line, you can smell the fragrance in the air. When romantic cloth art meets capable metal cloth art, the calm and gentle breath is overflowing. It has individuality does not make public, is composed with rich connotations. Between complex and simple, it found the perfect spot. The combination of the different lines and material makes the office chair emitting out a multi-level lasting appeal.



Evolution, my office form

Get rid of static state, or sitting or leaving, discussing, tea-tasting, take a sip, and enjoy my office life!

A1719

Here, each line is full of the tension of inspiration.



| Beauty of individuality

Tiffany Blue

People in young age don't need to worry too much, not need much rules of the game, refuse to play the part of others, just want to do the most authentic self. It is this individuality warm desire to ignite the creative ideas of the designer, FURICCO. Therefore, the opening wing style of clear line, publicizing individuality character is born in the people look forward to!



B1719



C1719

The texture of youth

Here, each line is full of the tension of inspiration.



B1719



C1719



A1719

Think about youth

Who betrayed the spring scenery? Who were young frivolous? Sitting here to write the stories of other people', to run my own life.



A1706

On Brand  Romantic, because of meeting it!

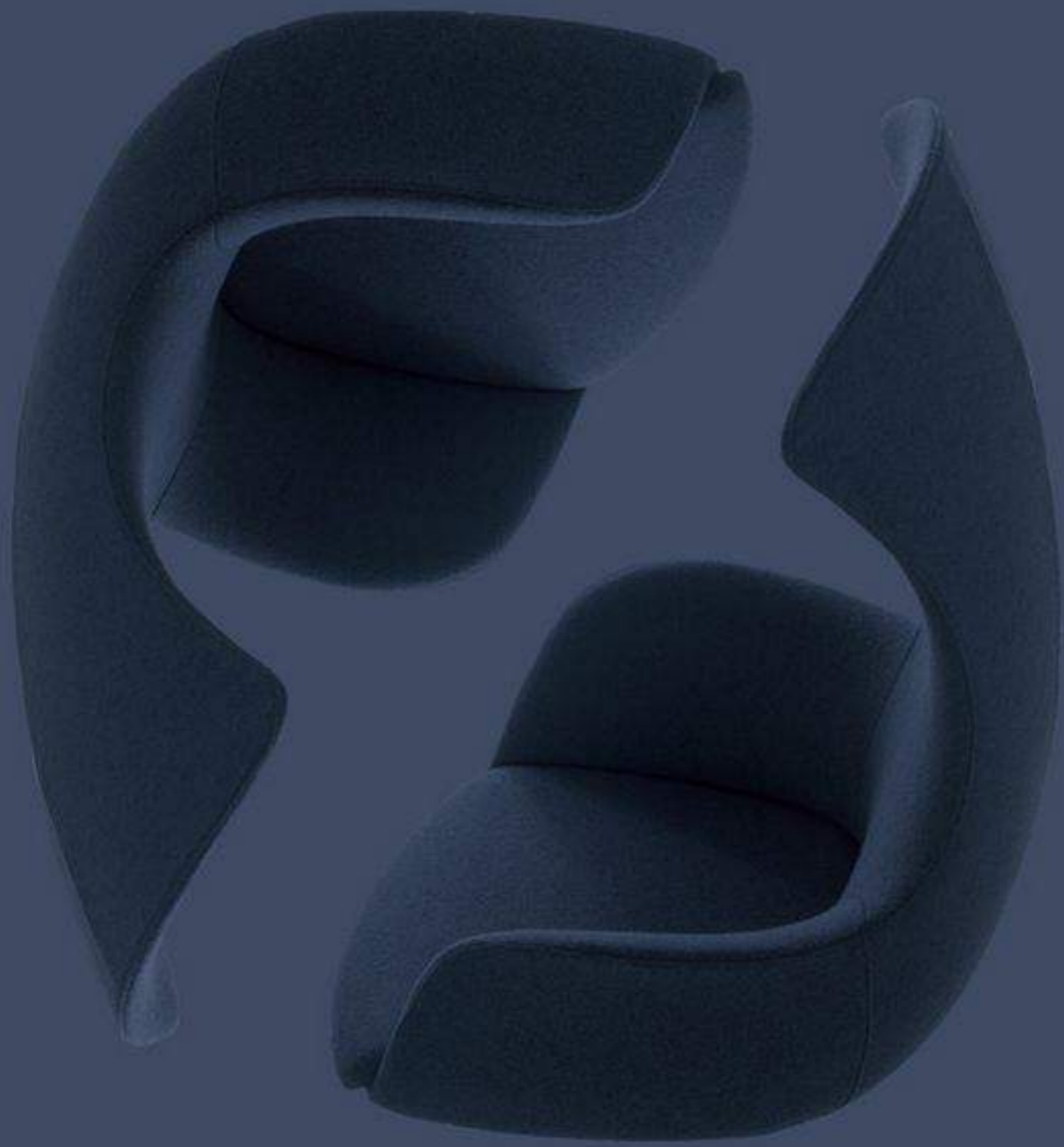

Beauty Shape

⌄ Romantic, because of meeting it!

⌄ With warm hugs and sit down

Miss it so much



A1706



A1706



Beauty Shape
Even if there is lack of sunlight in tall building, but we also can borrow a pulse to the close office chair the warm like fire, the excessive rationalization of office space, the pulsation of the heart happy.



A1706

Light Office  Light office, simple life



A1706

Light office, simple life

Make hard things simple, light, delicate and stylish, accord with the aesthetics of the golden ratio, reflect fashionable office temperament.



A1706

Fly With You



A1701



C1703-2



**Focus
on detail
2017.**

Only having the bright side cannot be regarded as the classics? The real masterpiece is naturally no fearing the test of any Angle. Here, no spare parts, every line has the reason of existence, and any details is making the best of it...the fashion power is hidden between technology and modelling aesthetic and here it is shaped into a full range of visual aesthetic feeling and excellent quality, also makes us knowing for the first time "a good chair doesn't only have the right for sitting ". The combination of decoration and utility, the mixture of the single use and combined use, this is new prominent design language

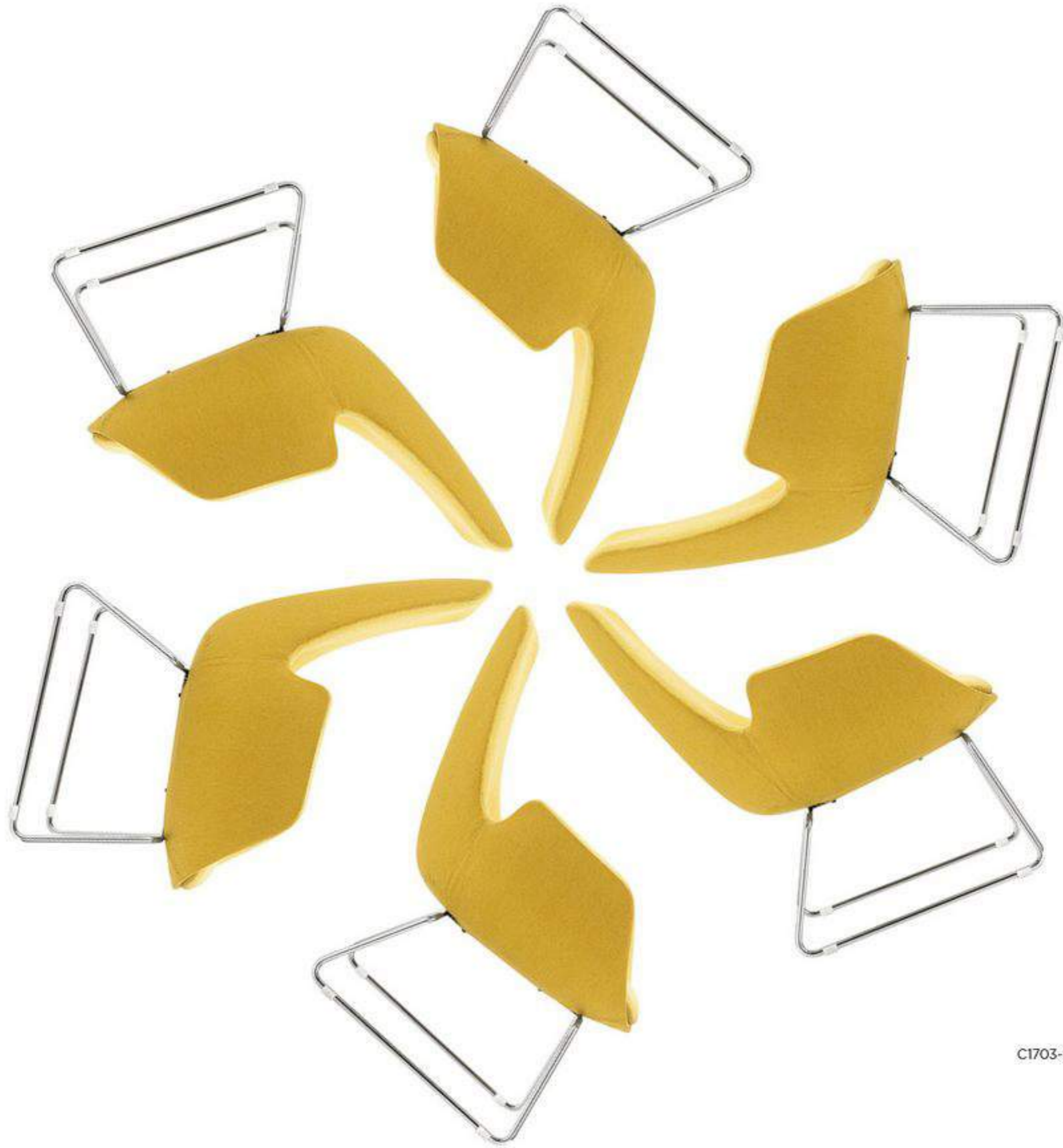

C1703-2

Angle Beauty

Angle decides the beauty

Yellow Chair

➤ Only there are details, then there are elegance



C1703-2



C1703-1

Wonderful Originality

The high quality flannelette with invisible zipper, not only maintain product design aesthetic feeling, but also is easy to keep and clean chair to be brand new for a long time.



A1703

Orange Men

Creating the graceful and restrained aesthetic sense by using the soft curve, with noteworthy conduct and independent character in the simplicity, in the grace, it more displays the charm and enchanting.



B1703

Young View



Living Office

Follow the feeling, refuse being
positioned!

Funny Working?

COLOR YOUR OFFICE SPACE



A1703

Intoxicated in the aesthetic and comfortable free space, pure and fresh, tranquil, soft is the close pleasure of our skin with the real leather. The experience of softness like, but don't know at this moment, who does sit with me?



A1703



B1703

Brand New

Seat modelling is inspired by the Indian poet Rabindranath Tagore "Life like Summer Flowers" in "Stray Birds". The young office life should be like the resplendence of summer flower, never faded and down, pretty and coquettish like fire, with gorgeous attitude to feel the movement of breathing and heartbeat, always enjoy it. With The simple material object modelling, the exquisite craftsmanship can be seen in the details. Between the light and shadow, it is intangible flowing.



C1703-1



➤ Due to simple, so love ..



A1726-2



B1726-2

On Brand

Away from the complex visual, between one table and one chair, it achieves the soul of the office, borrow a bit of tranquility from the plain color from nature, and continue the minimalism of Northern Europe.



C1726-2



C1726-1



A1726-2

Ust, conseqi tem fuga. Equae. Nam reperum imus mag dunt, cusam evendig nihilliquam, num eat et volenis eicitatur magnatus, sed enis arcium harcitibus idunt oditias sitaspi ciundus amusand enecearum expedis es sum eume dolorate natur?



B1726-2



C1726-2





KA-01L

B1720-1

Color Mixing Style

Difference between them is very simple, low profile and high profile!



KA-02L



KA-03L

Radian elegant, straight line, smooth transition, the double unification of the function and form and the dual satisfaction of sense organ and utility; the elegant and warm color is so passion, the natural revelation of the youth's mood. Fashion is not only a kind of representation here!



KA-01L

With the light wind and light floating cloud attitude, walk in your world!

Funny for Work, Great for Business



A1701

➤ With the light wind and light floating cloud attitude,
walk in your world!

Color World

The unique material combination, pure and fresh color is color matching, everything is the revealing of clever mind and show infinite modern aesthetic feeling.



A1701

My personal expressionism

Waltz of line



B1701



C1701

A1701



Appreciation

With the light wind and light floating
cloud attitude, walk in your world!

A1701



T1705

F1705

From delighted to thorough
A glass of water, a book, a person, a set of comfortable FURICCO office chair with foot pad, the work actually can be so comfortable.

Is it the momentary choice?

COLOR YOUR OFFICE SPACE



F1705



T1705



F1705

Happy to sit on it

Integrated chair style emits out the incomparable delicate and fashion sense. Matching with the independent foot pad chair, open a cozy space for your office for your meditation, or for taking a rest or nothing to do, quietly charge for the spirit, enjoy the pleasure brought from the modern office.



T1705



F1705



T1705

F1705



Besides the
exception



T1705

F1705

Blue Chair  find a comfortable position, enjoy the force of work change.



Natural style
Here has unique tranquility of the nature, also has the comfort that the nature does have!

T1703

F1703



The Scenery Of Thinkers

THE SCENERY OF THINKERS _

In the window of the office, set of comfortable chair, appreciate the scenery thought, enjoy with inner processing, the celestial pole are around and accompanying with us.



➤ Interpretation of fashion charm

My world is fashionable, because I use fashion to criticize my world, because of pickiness; it achieves my proud fashion office life. I chose FURICCO, what are you waiting for?



T1703

With the light wind and light floating cloud attitude, walk in your world!



F1703



Furicco  find a comfortable position, enjoy the force of work change.

Blue present for People, Great for Working

Fill a joy with the minimalist outline; draw the outline of poetic journey with rounded line. There is joy of travel time in the boring office life. Sitting in a chair is like making an appointment with self.



T1703



F1703



A1711



Perceptual Design

In the overall design, the emotional element of the perceptual element design makes the stylized administrative office some elegant interest



B1711



C1711



A1716



B1716



C1716



A1716-1



B1716-1



C1716-1



A1708



B1708



C1708



A1708



B1708



C1708



A1726-1



B1726-1



C1726-1



A1712



B1712



C1712



A1724



B1724



C1724



Excellent modern

The avant-garde style is from the creative inspiration. Projecting the surreal appearance at the appropriate time has become a source of fashion taste.

A1626



A1723



B1723



C1723

➤ Perfect, Will Never End

WORK STYLE BOOK

Living Office



ARTISTIC



**THE TRAVEL OF THOUGHT
IS LIKE TOUCHING THE
EDGE OF DREAM**

Here, all adjectives are meaningless, because the feet are more honest than the words



Black cool age, embraces the future together with you



A1904



B1904

Black sense of art

In the field of art, everything will be eclipsed without black. The fantastic realm presented by the dream is doomed to be highlighted by the elegant and fashionable black even with rainbow colors. The design of black chair may lack lively beauty, but must be full of fashionable and cool fashion. With different practical function, the art of chair in the dream will be reflected in the real space.



C1904



B1904



C1904

FREE STYLE

It is the free, bold and simple line that fits your body perfectly, with quiet elegant color to satisfy your elegant taste. The casual sitting posture, the unrestrained freedom will be started from the moment you sit on it



IN SILENCE

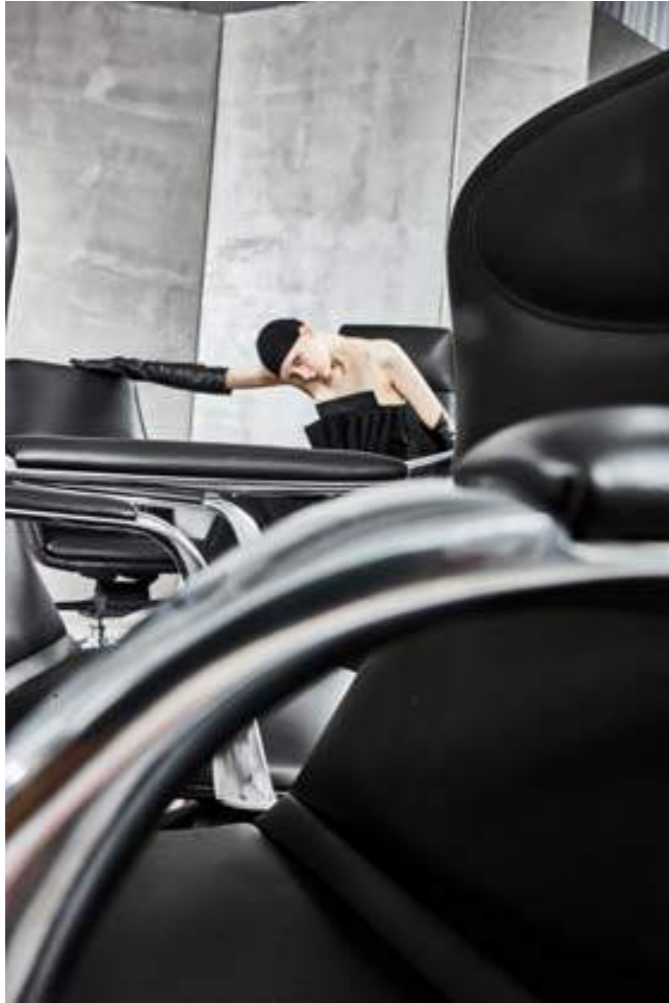

I ALWAYS WANT TO HAVE EXPERIENCE OF SITTING ON THE WORLD
MASTERPIECE OF CHAIR DREAMED FOR A LONG TIME





A1901



B1901

FROM THE FANTASTIC DREAMLAND TO THE AESTHETIC ARTISTIC CONCEPTION,
WE HAVE BEEN EXPLORING STEP BY STEP. DESPITE TWISTS AND TURNS AND
SUSPENSE, WE ALWAYS BELIEVE THAT THE MOST BEAUTIFUL ART IN THE
HEART LIES AHEAD



B1901



C1901

I never oppose life should be sunny and open minded, but believe that some arts can only be exclusively appreciated by someone, because some realm is inaccessible to people as some position be

WORLD MASTERPIECE



A1901-1



B1901-1



C1901-1





A1902



B1902



C1902

SIMPLE SHAPE CREATES PROFOUND MEANING



A1902-1



ARTISTIC CONCEPT

From the fantastic dreamland to the aesthetic artistic conception, we have been exploring step by step. Despite twists and turns and suspense, we always believe that the most beautiful art in the heart lies ahead



B1902-1



C1902-1

WORLD MASTERPIECE

I ALWAYS WANT TO HAVE EXPERIENCE
OF SITTING ON THE WORLD
MASTERPIECE OF CHAIR DREAMED
FOR A LONG TIME



ENCOUNTER MISSING

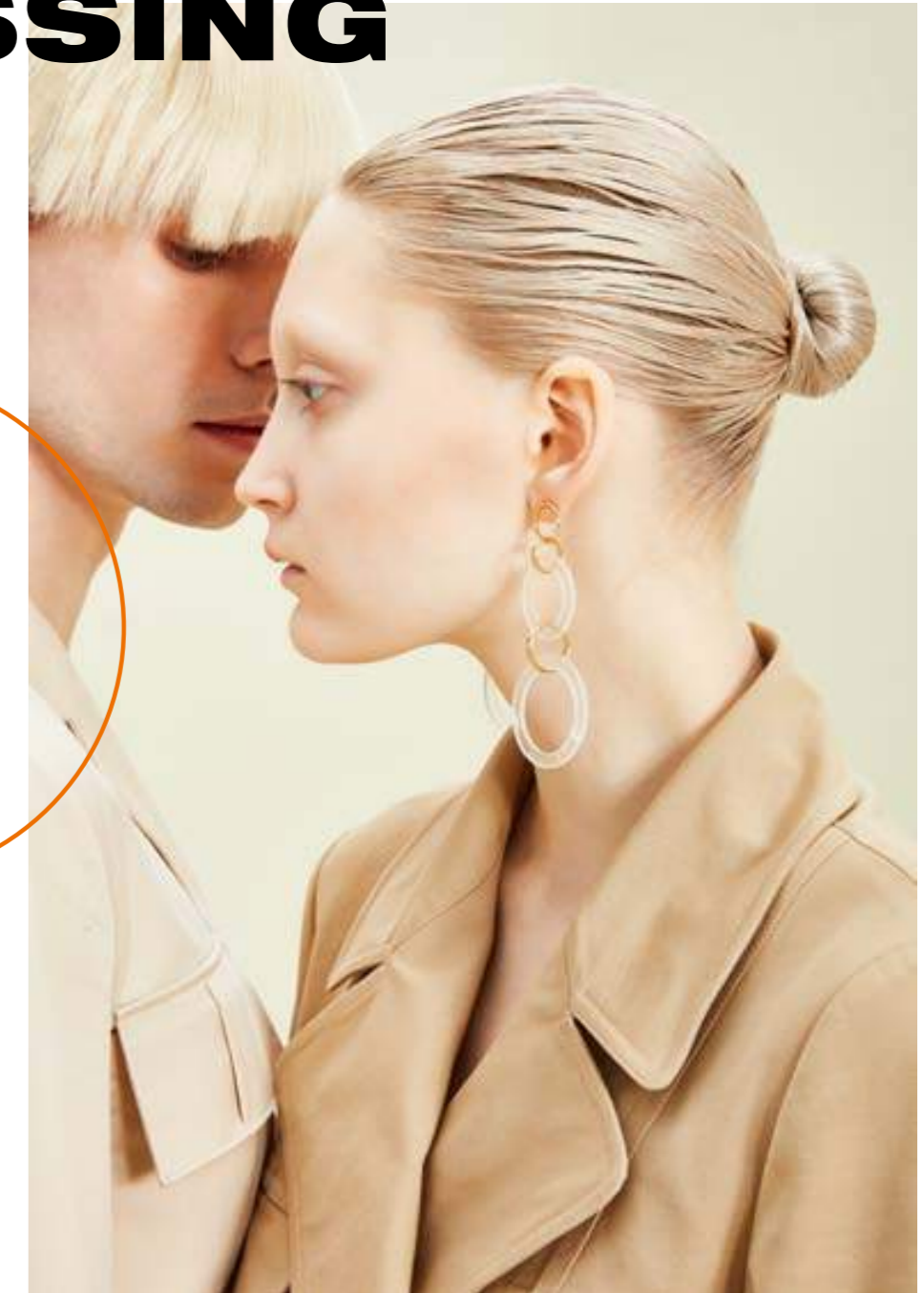

EVERY ENCOUNTER CONTAINS THE ULTIMATE BEAUTY

OFFICE STYLE

LOOK UP / DOWN

An ideological journey initiated by dreams has no fixed point of view and position, and it can be seen as a free rein between the artistic world and real life. Maybe it's a poetic space, a fascinating chair. Here, I forget the constraint, the rules, and freely enjoy the comfortable state composed by space and human



A1918

CURIOUS VISION

CURIOUS VISION

Beautiful things happen every day, but the most beautiful things are sought after once they are missed, which might be the reason that art comes from life but is higher than life. When we have aesthetic fatigue of beautiful works, we will be indifferent even they are so wonderful. However, we will contemplate and mutter afterwards, finding that it is the rare beauty in life





A1918



B1918

DANIMILLANDAE QUAMUSDA



C1918

It can be low pitch, or high profile.
With unique beauty of the art of
thought, it endows the real life with
luxurious soul. Even a chair contains
the strength of dream and realization.



Is the familiar feeling the scene in the dream or predestined in previous life?



A1918



B1918



C1918

It is for the dreams of young generation, for the successful people, because art and life have their own stratum. A chair carrying chair is no exception. The familiar feeling in the dream can reappear in the real life.



A1916



B1916



C1916

Furniture is the carrier of people interacts with the space, and the color of furniture also led the entire radiation addition to create high value of office space. The grass green vitality, the vitality of fresh ice blue, orange... Choose the right color of office furniture, to create ance of office space.



A1916



B1916

C1916

Idea of "Chair" in the space

It is design language interpreting the dreamer of life. An artistic feast is outlined by fashionable and sharp diamond lines, beveled interface and triangle image composition viewpoint.

**Irresistible beautiful
bewilderment**





FUNCTION



OFFICE

SEARCH FOR A POETIC ART, AND SHOW A PARTLY-VEILED BEAUTY. ALLURING EYE CONTACT, MAKES THE SEXUAL ATTRACTION NATURALLY RELEASED.



A1701-I



B1701-I

FUNCTION AND BEAUTY, IS THE PURE CORE OF ART OF CHAIR



B1701-I



C1701-I



ORTHODOX OR UNCONFORMAL? WE ARE GOOD AT
ACCOMMODATING ALL OF YOUR EMOTIONS



Life is like a seesaw. Whoever is taller or lower depends on where you put the fulcrum.





B1912



B1912



B1912



B1912

The shape is condensed but not insipid, simple and plump. The line is smooth but not dull, gentle and upright. The colour is pure but not monotonous, bright and quiet. Their elegant and concise temperament always lets people ignore their other perfect functions.

Function and beauty, is the pure core of art of chair



C1912-1



C1912-1



C1912-1



C1912-1



C1912-2



C1912-2



C1912-2



C1912-2

AMAZING





A1908



Breakthrough the shackles, only for amazing the future

The simple and pure colour, the exquisite surface treatment, the lightness are admired by people. The style, material and technical means even show the endless charm and bearing of modernity



B1908



B1908



A1908

Those concise works, fluent lines, through the wise and lively combination, become emotionally rich and meaningful existence, opening up a place to stretch one's own taste in the noisy urban business space.



OFFICE STYLE

ENCOUNTER



B1908



C1908



A1908



A1908

Lost in a relaxing and free space with fashion, quality, placidity and gentleness, it is the joyful skin-to-skin experience, and a soft feeling. But who will sit with me here at this moment?

Encounter

Lost in a relaxing and free space with fashion, quality, placidity and gentleness, it is the joyful skin-to-skin experience, and a soft feeling. But who will sit with me here at this moment?



LOATH TO DEPART



BRAND

THE FAMILIAR CALL FROM THE DREAM



LOATH TO DEPART



OFFICE

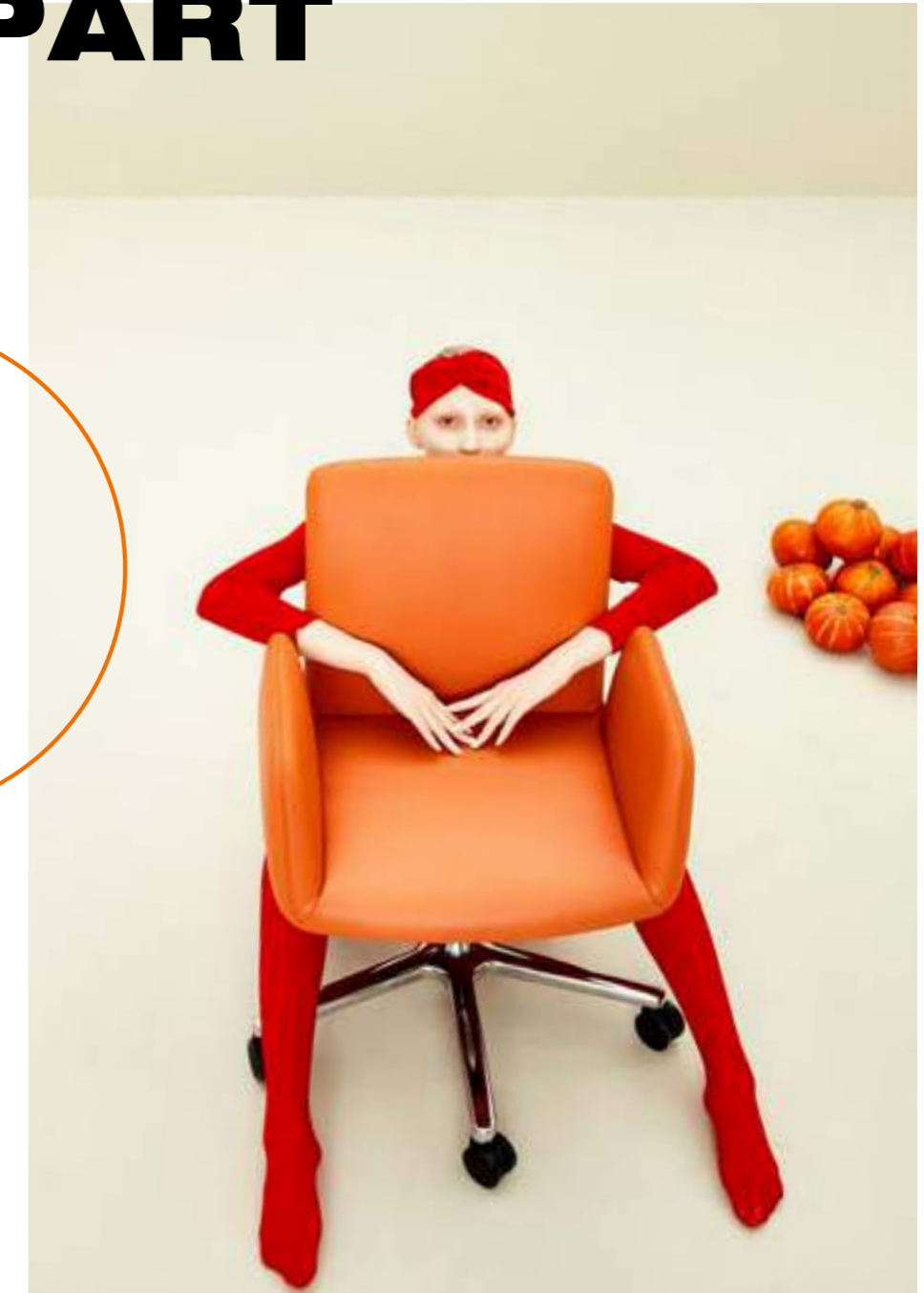

SEEK AND ENCOUNTER. ONCE ENCOUNTERED, IT IS THE ARDENT LOVE THAT CAN NOT BE PARTED WITH



B1906

**OFFICE CHAIR GIVES
THE SPACE A FULCRUM FULL OF
ARTISTIC SENSE**

THE ARTISTIC SENSE BETWEEN THE SQUARES



C1906-1



C1906-2

ALL-IN-ONE

All-in-one shaping technology and artistic color bring concise and delicate taste to the space, together with comfortable sitting feeling and modern temperament, each chair here has become an ideal choice for decorating high-grade space



B1906



C1906-1



C1906-2



Be your own queen in your space





F1926-1



F1926-1

Mood like flowers in full bloom

Nature is the great mentor of human beings, and it has taught people all aspects from life to art. The shape of nature flowers is used for reference for the design of the single chair. It is delicate, natural and beautiful. Every moment when you sit on it, your mood will be like flowers in full bloom.



F1926-2



F1926-2

ENJOY

THE FEELING OF BEING SURROUNDED BY ART





WARM ROSE

ROSE RED AND SHAPE OF FLOWERS



B1925-1



A1925

The office chair has warm rose red and shape of flowers, which looks like a flower that never withers. It can bring enthusiastic and romantic breath of the nature for concise business space.



B1925



C1925



C1925-1



A1925



B1925



C1925

THE FEELING OF BEING SURROUNDED BY ART

**Concise and practical design is
also full of family affection.**

Standing still in the corner, it is like a spirit falling into the world. I hope to enter your soul in my own way. Someone pulls me, it is he, not you. So he can only dance, shake off lonely thoughts, but still is very happy until he removes sadness and achieves nirvana, and feels exhausted.



CONCISE AND PRACTICAL
DESIGN IS ALSO FULL OF
FAMILY AFFECTION.



A1920



A1920

IDEAL JOB

The smell of youth is floating in the air. With a different mood, familiar but distant, cordial but strange, it is really good to always expect something every day.



B1920



C1920



As long as you dare, there is the ultimate art.

Here's your place! Release your thoughts, desires, individuality as long as you dare.



F1903



T1903

Life is beautiful, right here

The value of life not only includes constant pursuit but also enjoyment. Sometimes it is also very beautiful thing to slightly stop the pace of running, fall on a comfortable chair, pad up tired legs, sitting quietly, doing nothing, just thinking of something funny.

Comfortable living is an ideal job





SPIRIT THAT FALLS INTO THE WORLD

Standing still in the corner, it is like a spirit falling into the world. I hope to enter your soul in my own way. Someone pulls me, it is he, not you. So he can only dance, shake off lonely thoughts, but still is very happy until he removes sadness and achieves nirvana, and feels exhausted.



A1911

Lightweight and stylish

It scientifically interprets the ergonomics, and is the integration of shape and function, creating the elegant and effective working space for you



B1911



C1911-1



C1911-2



A1911



A1911

MINIMALIST STYLE

Urban architecture exudes a calm temperament. Its straight lines are used as design elements to outline the square and majestic urban space and remove impetuous urban atmosphere.



B1911



C1911-1



C1911-2

LET GO YOUR SOUL

In such a space, you can let go your mood, and pursue the endless aspiration





A1921



A1921

Based on the keen sense of The Times, profound artistic foundation, exquisite technology, the designer artistically reproduces the most appealing fashion elements from life in the works. Perhaps this is an integral theme of chair art.



B1921



C1921



LET GO YOUR SOUL

**APPRECIATE THE CONFLICT
AND DIALOGUE BETWEEN ART
AND LIFE**



F198



F198

The designer believes in simplicity supremacy, uses elegant arc lines throughout the whole works, and forms the system design. Back of the chair, cushion and armrest adopt circular arc element, which deduces elegant fashion.



F298



F398

SELF BEAT

The convention is decided by me. Youth is not decided by convention, and convention can never stop our young heart. I have my opinion. This is our chair story.





A1826



B1826



C1826



A1800

MINIMALIST STYLE

It is the ideal seat in our dream: fresh colour, pure and agile type, and no a trace of superfluous complexity.



C1800



A1816



A1816

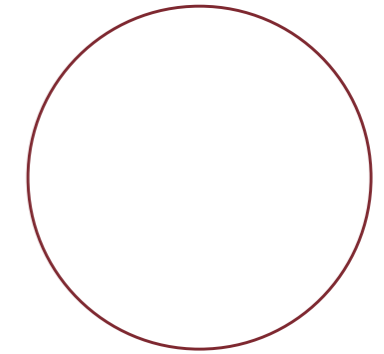

ARTISTIC PARADISE

The rose red on the chair denotes the yearning at the hidden bottom of your heart: a pure world, halcyon, beautiful and dream-like scenes, without any outside disturbance.



B1816



C1816



C1816-2

ROLE BACKSTAGE

Roles need to put on a professional mask, build up visual lines on the body, and fully perform their own scripts in the front of stage. The professional smiles and exaggerated expressions may not be the same as their real emotions. The emotions of social roles are left behind with the clothes they have changed.





It is enchanting, implicative, looks wonderful, seems to be a gentle flower blossoming in every corner, and has no painstaking decoration. It is quite natural, and about intimacy, sadness, and soul.



A1816

ART PARADISE

In the face of more and more abundant materials, people yearn for simple comfort, would like to throw off all trifles, fetters, heartily enjoy the purely beautiful life. The simple and comfortable chair creates an artistic paradise of the soul.



B1816



C1816-2



Angle

Rodin once said "Beauty is found everywhere. Our eyes do not show a lack of sense of beauty, but a lack of observation". In many cases, people can discover unexpected beauty in aesthetic art, work and life as long as they observe from a different Angle.

Joyful Colour

INDULGE IN INDIVIDUAL HILARITY



C1924



C1924



C1924



B1924



C1924-1



B1924



B1924



C1924-1



C1924-2

The dream language opens an ideological journey about chair art, which enables people to shuttle through the vast and boundless art world with the help of unbounded thinking, explore the latest inspiration and international art trend of thought, and finally form visible and eye-catching works, waiting for your appreciation.

Always looking for a place to tolerate self-indulgence. The dream job enables people to live out the true self.



FREE SELF





FREE SELF

The more rules and regulations there are in social work, the more people yearn for freedom in heart. Even if they cannot completely free themselves, at least they hope there will be a space to accommodate self-indulgence. It integrates comfort and image, work and freedom. This is the ideal goal and the chair art in dream.



A1819-1



B1819-1



C1819-1



B1819

The fashionable office chair designed for young administrative staff. The first class imported materials, clear cut and simple line, exquisite and flawless craftsmanship, all fully condense excellent quality and personal taste, allowing harmonious beauty to show thoroughly.



C1819



A1819

MINIMALIST FLEXIBILITY

It is freer to make complex things into simple. The designer follows the simple and extraordinary design, mixed yet orderly concept, presents minimalist flexible shape, and practicable functions. The beauty of light simplicity can be perceived in life.



Artical



ARTISTIC IMAGE

Gain an attraction outside **your field of vision**



Artical

I once thought that it was ok as long as the chair was comfortable, durable and good-looking. I didn't realize how much I had missed until I met her. The most important thing was that I ignored my own inner feelings. From this moment on, I do not get busy for anyone, but focus on the art of the chair and my own inner feelings.





C1909

Gain an attraction outside **your field of vision**



B1909



B1909-1

ARTISTIC IMAGE

Awake



C1909



C1909-1



B1909



ARTISTIC IMAGE

**SPECIAL
CHARM**





A1719



B1719



C1719

SPECIAL CHARM

Black looks composed and steadfast. The eye-catching bright electroplate hardware looks like starlight in dark night. They let people yearn to be close to, but cannot be satisfied.

BEAUTIFUL ARTISTIC IMAGE FEELING





F1823

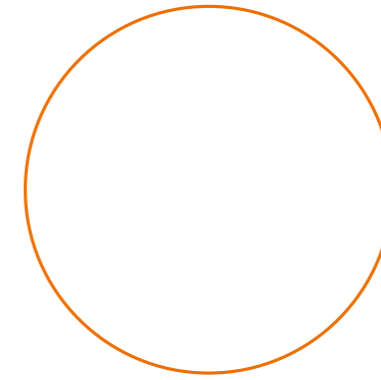

BEAUTIFUL FEELING

Boundary limits freedom. The design saves the traditional handrail, looks exquisite and magnificent, and gives users greater freedom. Due to the unrestrained bearing, there is unrestrained body language. This is the art of the chair, and the pursuit of the soul.





A1708



A1708

ARC OF DREAM AND REALITY

Carrying the high quality design gene of the fashion, it is lightweight, diversified and fashionable. Inheriting the excellent FURICCO technique, it pays attention to fashion trend and the wish of the users, beautifying the office environment and improve team effectiveness.



B1708



C1708

ARTISTIC IMAGE

EXTREME IMPRESSION



NOBILITY

BE ENHANCED



The deep black of high grade cowhide represents nobility, symbolizes profoundness, frankness and freedom. It triggers the inspiration and originality of furniture designer, and adds more room for the imagination space of the designs.



A1927



B1927



C1927



A1927

EXTREME IMPRESSION



B1927



C1927



A1822



B1822

DANIMILLANDAE QUAMUSDA

The designer gets artistic inspiration from the world classic "bear hug chair". The short and fat armrest extends, it seems that it hugs the young bear. It is equipped with comfortable stretch force material filling and has remarkable surface texture sense, so people would like to always sit down. The combination of simple plastic arts and scientific structure gives good moving support. It is comfortable, stylish, and high-end.



C1822



F1808

Arc of dream and reality

Beautiful and fluent circle arc makes the low chair rich and fruity. The free design is a bit redundant, so you can feel free when sitting there.



F1824

Dancing butterfly

The romantic designer creates the dancing butterfly image on the back of the office chair, which brings the vitality of nature to the inanimate chair, and makes the mood alive.

THE IDEAL OF THE CHAIR



F1703



F1703



T1703

It keeps pace with the pulse of times, displaying the fashion lifestyle, combining the modern office latest trends, innovative, advance guard, open and personal. It allows people to experience fashionable frontier, appreciate the new elegance of modern office art.



F1703

dream

OFFICE STYLE



Pressure-free sense of beauty in life

Every day's work is like a holiday in the own seat. The quiet and elegant colour tells the yearning for a quiet life. It fits the curve of human body, and embodies the extreme pursuit of health and happiness. Some people, who are naturally tired of the boring work mode under the traditional mode, choose to job-hop and escape. By comparison, I choose an artistic chair to release the pressure of body and mind in the work seat.



F1821

T1821

THE IDEAL OF THE CHAIR



F1821

FRESH IMPRESSION

THE DOT LINE SURFACE PRESENTS ELEGANTLY; THIS IS THE FREEHAND BRUSHWORK OF CHAIR ART.



F1705



T1705

FRESH OF IMPRESSION

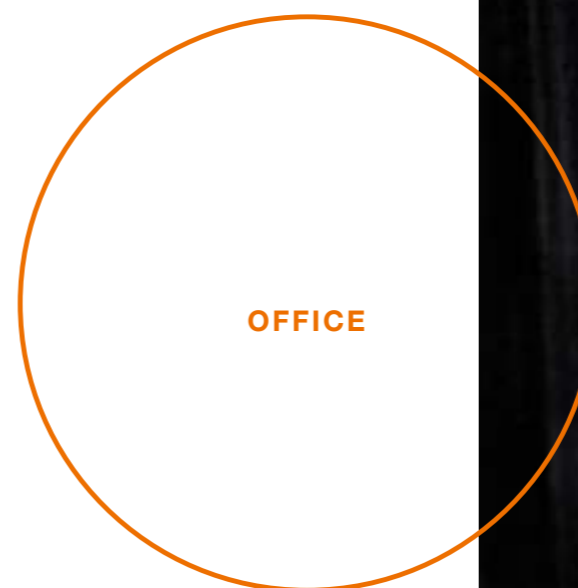

OFFICE

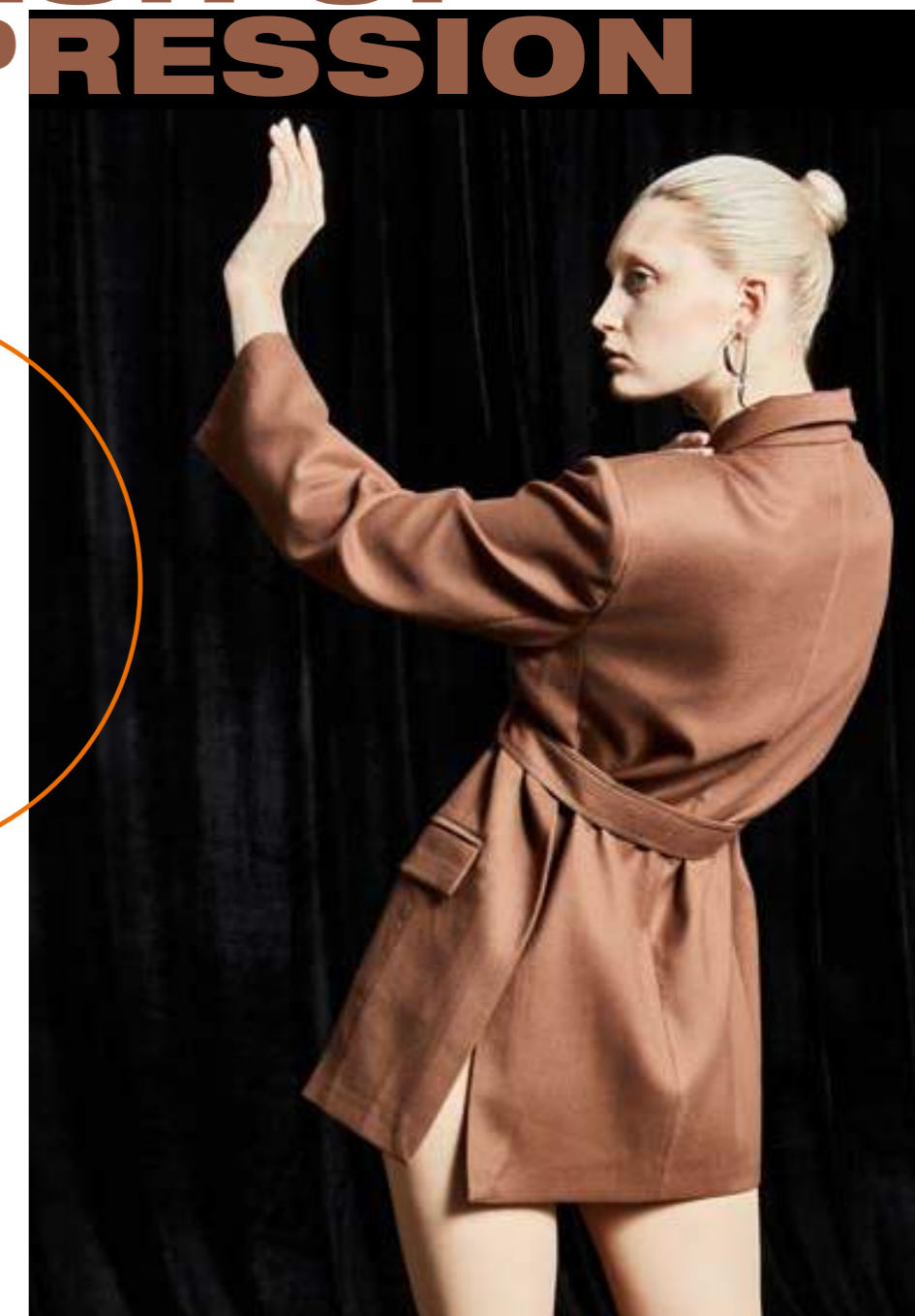

ART IS INTANGIBLE, BUT CHAIR IS TANGIBLE. FURICCO GIVES YOU THE FASHION ART THAT YOU CAN TOUCH.



C1807



C1807



C1803

The perfect colour creates perfect beauty. The great sound seems soundless, the great image seems formless. The interpretation and analysis of perfect beauty needs depth of appreciation by the mind.



C1803



C1803

Directed by

Change The Vision Of The Habits

The magic master of achieving dream
FULLY PERCEIVE THE BOTTOM LINE OF BEAUTY



F1824

New Collection



Uneasy restless heart, always
eye covetously behind the rules
of the tiger, quiet patience,
only for some time

Walk the same way every day, and you will feel a great deal of ease.
But wanting to stimulate the life, you need to deviate from the original
track or that piece of land, it is that you, because article dare to by the
mainstream under the frame of unreasonable, by the world feedback is
breathtaking beauty) am rule breaker - Fulcoo New Look

2

There is no extreme beauty coming from?

Things of one kind come together, and people of one mind fall into the same group. Life constantly chooses the people who can get along well. In fact, because it has made head, it has another tail with which it does not do without, but cannot suppress. Have ideas, and get them someone to break the wall and everywhere, everything becomes clear. This kind of being is very beautiful in my opinion, just like I sit on a custom-made chair to enjoy the beauty of the night.



F1824

To
the Stars

Provoke_ART*

You can't understand this low key if without a certain height.



Dream may be lonely, but passion will never extinguish, if it only last a chair with accompanying with me. I will sit on it to start my era.



F1823



New Collection_2018



I chose simplicity while others were busy filling their lives. I chose a comfortable chair and sat down to watch them when others desperately want to get ahead in the world. Passing by the times of material madness, I enjoy the new look of the heart.



F1823

The Profound cultural background and traditional abundance breeds the delicate craftsmanship and masterpiece. Every day we are constantly exploring more sophisticated technology, choose more precious wood, tan more top leather, spin more delicate fabrics. Each New Look products stand the test of time, has become the sentimentally refuge of different experience.

Breakthrough, is the soul noun printed in the brand New Look, accompanying with the development of the birth of the series and brand personality and enduring modern urban elite of beauty and taste and living inspiration, and meticulous attention to detail, to shape the New Look outstanding in the field of modern office chair image derived from the spirit of craftsman in Italy's top luxury and the elegant combination of modern light luxury thought, became the New Look and style and quality assurance.





Provoke ART*

The art of provoking the mind



SOUL

All New All Beautiful

Uneasy restless heart, always eye covertously behind the rules of the fight, quiet patience, only for some time.



The escapist in art

WORK STYLE

Living Office

Don't be office
evolution limit

2 Inspiration _ART*

For the office chair color required office space

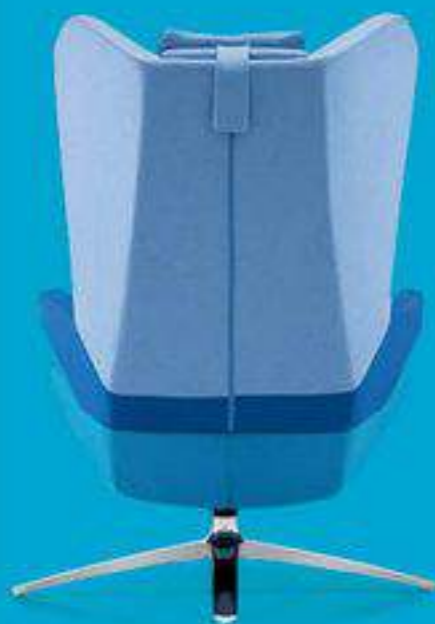

F18.2B

When I was a child, I often envied the plane fly freely, after growups, I wake up that is if more freely seeing plane flying than travelling by plane. On the chair with agile line, the designer arouse our childhood dream, the dream when awaked up, it real beautiful more than sleep that.

Living Office
In the office
with the star



F18.2B

COMPLICATED AND SIMPLE, ALSO IN VERY PURENESS

Image inspiration from the fold line of paper airplane, make people round a circle and draw a star to find a original beauty.



F1828



F1828



Ergonomic ideas support the soul of the innovative design, here every line of more than ten thousands of combination of the group of adult body data, because the need of subjective feelings, but comfortable tend to scientific support



CURIOUS



Interview

The existing views is about up the fashion world. Puzosido, magis, gory, and Puzosido New Look, are born the same thing, make you no longer know you are already familiar with the world. To this end, we have been actively seeking to overturn the existing opinions you have on fashion.

Arbitrariness and williness of refined calculation

WORK STYLE

Some people think that abstraction is chaos, casual is arbitrary. In fact, all seemingly random strokes need through linear precision calculation, having a pen that whether the performances of Pompidou magic group, or Furlco New Look, you will have strong feelings of it.



C1816





THE SPACE ENVIRONMENT ART

FASHION ATTITUDE

Constantly create more fashionable and aesthetically beautiful office space.



The extreme lines are gradually clear, the meridian of design is gradually clear, as if the temperament that can touch has already outlined a magnificent fashion life, shock and awe, more dramatic.

With new ergonomic research combined with postmodern main aesthetic sense of simple design style, like the silence in space magician, instantaneous light office environment and fashionable temperament, make all workplace aesthetes are obsessed



B1816



B1816



B1816



B1816



B1816



B1816



The Beautiful Magic Light Up The Space

Between the voice and mathematics, have you heard screaming and a kind of it's all and buds happiness, is a random shaking caused by noise... warm grace of sexy rose red, matched with the flower pattern seat modeling of human body engineering design, make you, the person of relaxing to happy don't want to leave it once sitting down on it. The young office space needs to ignite passion, makes the flower of life revealing romantic passion.



A1706-1

With new ergonomic research combined with postmodern main aesthetic sense of simple design style, like the silence in space magician, instantaneous light office environment and fashionable temperament, make all workplace aesthetes are obsessed

LIGHT UP THE SPACE AESTHETICS



A1706



Magic Line

THE BEAUTIFUL MAGIC OF THE LINES

The extreme lines are gradually clear, the meridian of design is gradually clear, as if the temperament that can touch has already outlined a magnificent fashion life, shock and awe, more dramatic.



A1719



B1719



C1719



The texture of youth

Here, each line is full of the tension of inspiration.
在这里，每一线条都充满了灵感的张力。

| Beauty of individuality

Tiffany Blue



B1719



C1719



B1719



C1719



A1719



The surpassing of the thought

The world looks like is very big. In fact there are invisible glass wall which is obstructing our thoughts. The slowly default brain for the world is like that Persepolis magic greed will give us the biggest inspiration is, in fact, the world is not fabricated the brain, as long as the mind across the invisible wall, we are in the world will become a shape

It is not necessary to be too involved in the reality of what is in front of you, as long as you are fully immersed in the experience, you will experience the extraordinary beauty, the magic is the same, and Perleto New Look chair is also like it.



F1705

The space environment art



F1705

时尚的色彩打开无限的可能，如同置身于工业风环境中的时尚艺术，将空间艺术化为环境艺术。
The fashionable color opens boundless possibilities, just like the fashion spirit that jumps in industrial wind environment, turn dimensional space into environmental art.

Create The Ultimate Pure Beauty For You

CREATE THE ULTIMATE PURE BEAUTY FOR YOU



T1705



F1705



Is it the
momentary
choice?

COLOR YOUR OFFICE SPACE

F1705



Happy to sit on it

Integrated chair style emits out the incomparable delicate and fashion sense. Matching with the independent foot pad chair, open a cozy space for your office for your meditation, or for taking a rest or nothing to do, quietly charge for the spirit, enjoy the pleasure brought from the modern office.



T1705

F1705

Provoke ART*

interpretation of Astor's design



T1703



F1703



The Scenery Of Thinkers

THE SCENERY OF THINKERS _

In the window of the office, set of comfortable chair, appreciate the scenery thought, enjoy with inner processing, the celestial pole are around and accompanying with us.

② Find a comfortable position, enjoy the force of work change.



F1703

③ Select a beautiful office chair, ignite the brilliant color of office.



My world is fashionable, because I use fashion to criticize my world, because of pickiness; it achieves my proud fashion office life.

The pure appearance of cloth art contains the unwitting low-key of the 80's people. The artistic stretch of the petal type modelling achieves the multiply comfortable leaning, always is so clever, pleasantly taste FURICCO, bring poetic embrace to you



T1703



F1703



MAGIC

Style



F1808

Living Office

Use the office
redefine time

People-oriented design essence, pursue of the aesthetic feeling of the appearance, pay more attention to the combination of the curve and the human body, break through the old thinking, the illusion of aesthetic feeling into the office space.



F1808



F1808

THE ADMIRING AND AMAZING EXTRAORDINARY STYLISH

Some people think that fashion is luxury, some people think that fashion is simple and sometimes, fashion is just for expressing individuality, your attitude towards fashion is just like your attitude towards life.



F1508



C1807

Adhering to the traditional craft, combining modern art, noble and elegant design, exquisite and unique craftsmanship, it is refreshing science and art perfect combination, elegant and practical, comfortable and considerate.



C1803

PROVOKE



Excellent quality

The meeting table furniture with Nordic impression is taking "less is more" design philosophy, for the exquisite grade, style, rank of Social upstart of the people who were birth in 80 years, we build the lasting appeal, free and natural, clear and pure and fresh office furniture high quality products which have elegant style, with the elegant line, pure natural color, non-carved plain, gives people the sense with delicate and elegant, polite manners, satisfies the rich connotation of the modern elite grade who are pursuing of Buddhist mood, ethereal and minimalist luxury high aesthetic.

SIMPLE LUXURY AND NATURAL

No matter it is the extremely simple geometry, or is the bathed the natural color like the spring breeze, all is rendering to true attitude of life, brings office space a meeting full of northern wind environment for us, with enjoying the pleasure of success, all embrace of beauty style

THE SPACE ENVIRONMENT ART

FASHION ATTITUDE

Constantly create more fashionable and aesthetically beautiful office space.



C1803

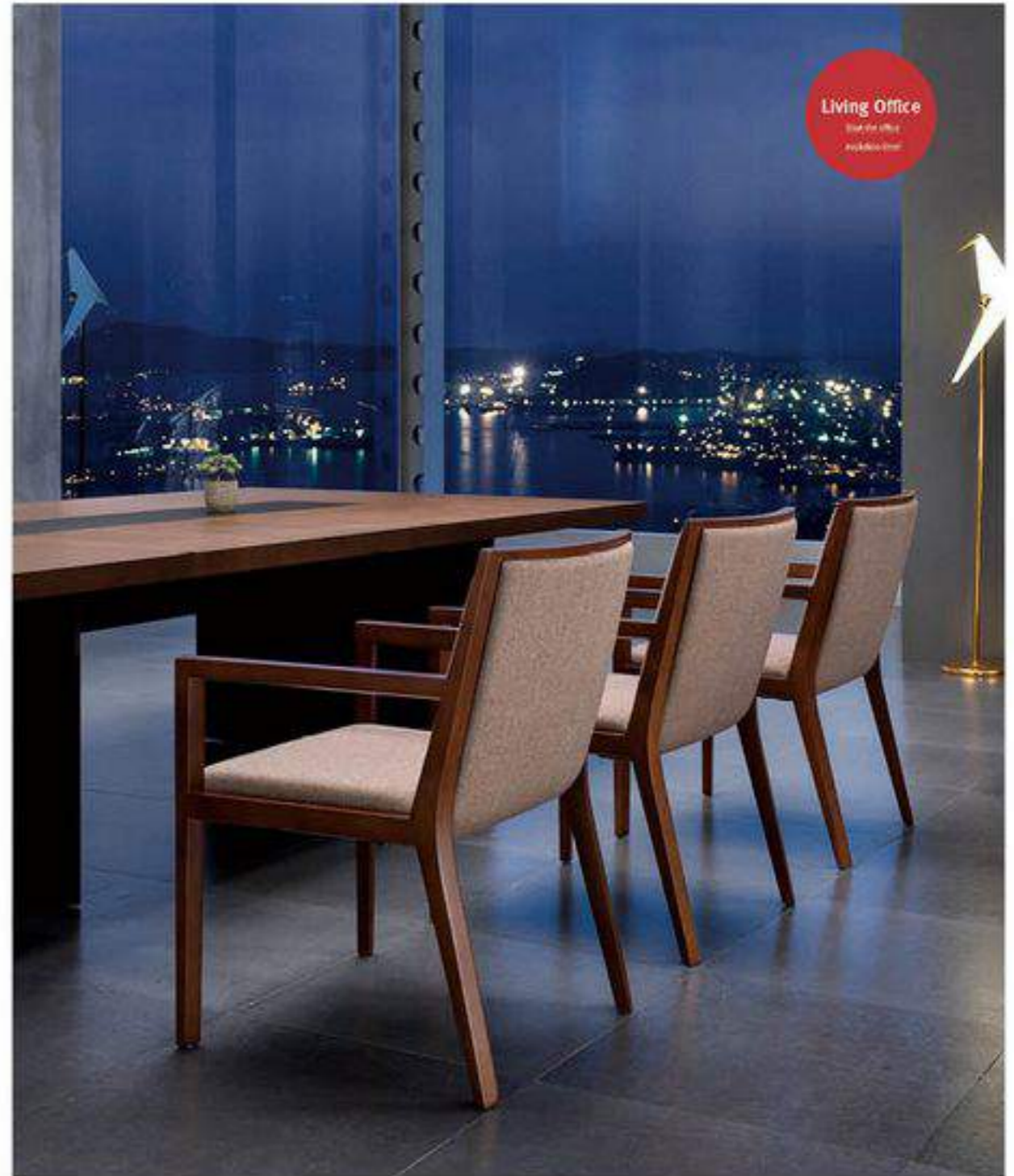

THE ADMIRING AND AMAZING EXTRAORDINARY STYLISH



NEW CONCEPT

Constantly create more fashionable and aesthetically beautiful office space.

The real magic is not to create unreasonable things, but to allow a reasonable things in a way that is beyond common sense, this is the magic of " ". is also Farco New Look office chair in design and production process, all follows the principle of design and art motive force of the breakthrough, is all for pleasing people



F1820



The inspiration comes from the jellyfish, known as the moon in the sea, which uses the soft curve to create a graceful and graceful feeling. In the simplicity, it is more unique, and the charm is more enchanting.

Sensuality ART

Sensuality is a fashion.



© HERMES PRINCE PRINCE 2013

HERMES orange, Carter red and Louis Vuitton brown color are not just a light in our eyes, in the synthesis of feeling, also represents a unique and individual character grade, the color cannot between high and low points, but there must be a beauty and grade difference, Fast to low Look, with a variety of different color, there is always a way to further your grade.

B1022

THE ADMIRING AND AMAZING EXTRAORDINARY STYLISH



A1822



A1822



C1822



B1822

The unique style of modernist, the excellent design with elegant and nimbus, the dignity covered in the nature, can greatly satisfy customers comfortable. The three aspects of practical aesthetic requirements give you an elegant romantic leisure environment

The seat board and the backrest synchronously move, always maintain the most comfortable state.

1

THE WAIST AND ARMREST ARE COMBINED AS ONE

LEANING BACK LOCKING

2

EACH DESIGN IS AIMING AT THE DEMAND OF THE USER, AND THE APPLICABILITY AND COMFORT HAS ALWAYS BEEN AN INEVITABLE WAY OF THINKING.

THE SPACE ENVIRONMENT ART

FASHION ATTITUDE

Consistently create more fashionable and aesthetically beautiful office space

6





WORK STYLE

NEW CONCEPT

The high technology realizes the high difficulty curved arcs of surface, radiates the unique temperament of the real leather and metal collision, more three-dimensional filling.



The high class office chair is every relative work partner of the policy makers, managers, their different styles and quality not only represents the leader's personality and its successful demeanor, at the same time, makes more personal talent playing fully, and grasps the present and the future of my career. Furico New Look high class genuine leather office chair model is made by using bionic design, introducing and introducing the design of the human body, the back arc conform to the degree of curvature of the human body vertebra, can effectively prevent sitting back ache, the force body of the whole product mechanical body is made using the high strength produced by high quality stainless steel, durable and has a good support and collision effect. The high-quality impounded pure black cowhide style of unique fine texture, combined with the natural appearance and solid protection function, conveys the concept of comfort and protection of the human body.



New Collection



D356

The inspiration comes from the 19th century classic French high back armchair, wide seat Back of a chair with fine delicate metal foot, compared to a slightly bizarre beauty, combined with the towering a spot in the back of a chair to create a pleasant and comfortable oasis



Living Office

Start the office
with a bang

COMBINE ART AND WORK TO PROVIDE MORE EXCITING POSSIBILITIES.

Directed by
**Each painting Is
An Expression Of
Inspiration.**

THE ADMIRING AND AMAZING EXTRAORDINARY STYLISH



T1621

F1621

FASCINATED COMFORTABLE FEELING



In life, everybody generally has such a consensus, that is making the body lay down with 135 degrees, it is known the most comfortable pose, you can read, can taste the wine, when you are tired, you can just casually throw down objects and fall asleep...we do not know how higher-ups you were the first to find this angle of 135 degrees, and even don't know whether it is real science, but the most beautiful life is not needing the superstition and requires a certain mystique? With a 135-degree backrest and an elaborate footstool, Furico New Look opens up a free and relaxing space for you in a rational office space.

F1821



MAGIC STYLE



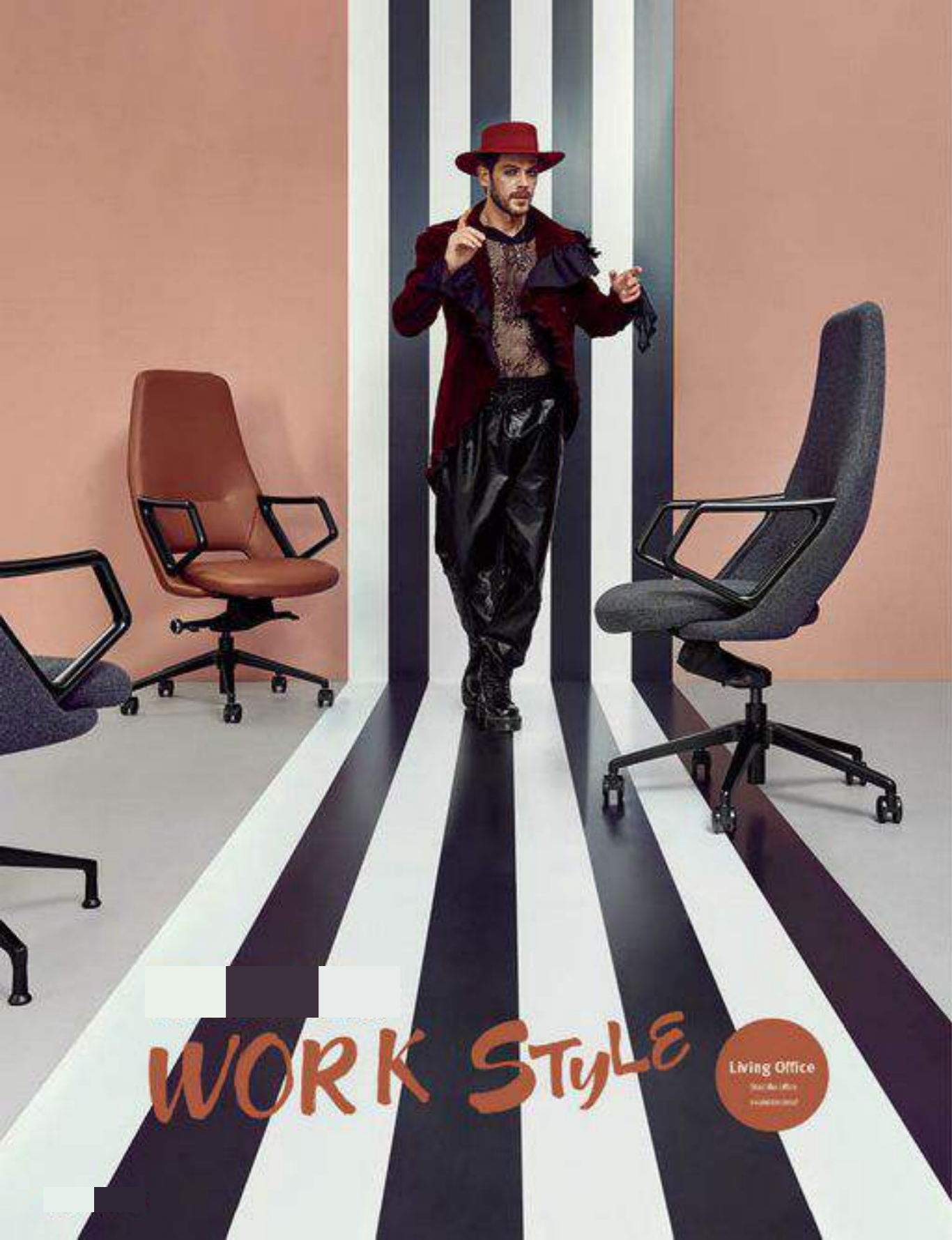

A1805-1



B1805-1



C1805-1

FASCINATED COMFORTABLE FEELING

We got the for inspiration from Pompidou many brilliant performances from some famous magic group, combined with 100,000 groups of human body proportion parameter optimization selection, took four years of repeated carve, have rich Furico New Look and style and features of impressive New Look New style as an example of a fashionable beauty and ergonomics, it pays attention to psychological and physiological feelings of the people, between science and humanities, open high-end feeling brand New performance.

The design of the unique appearance is more appearing to charm of the product.

CONSTANTLY CREATE MORE FASHIONABLE AND AESTHETICALLY BEAUTIFUL OFFICE SPACE

ELEGANT FASHION

2

The seat and sitting down, in our life is a contradiction of the complex. The sedentary and health, the correct posture and comfort, the aesthetic perception and utility... in creation Furico New Look and style and features, is to balance as soon as possible, and even to solve these problems, this is why we call it space magic New Look is the creation of a New style of the long planning and the results of the whole Furico team.

PROVOKE

The cool style and modern design detours the impressive appearance, unique classic lines, flexible adjustment mechanism, combines the elegant and healthy taste feelings, more reveals young leaders otherworldly business style



Black cool fashion



A1805-1



B1805-1



C1805-1



C1805

FURICCO / 095

Sleazy plating armrest, like eyes light up black leather color aesthetic feeling, deduce as wonderful as fashion devil LV and free from vulgarity beauty of black and white like asymmetric line of carefully, learned the chair of the clever breath



B1805



A1805

FASCINATED COMFORTABLE FEELING



A1800



A1800

Modern office space, always need some simple single chair to fill the whole space planning cannot achieve the flexible function of Filisco to provide you with a series of different colors of odd chair choice, they may not be able to become one of the important position of leading role, but certain essential.

more importantly, when you need to be able to fit easily into a variety of office environment, convenient and practical, beautiful and easy

The seat board and the back of the back synchronously move, always maintain the most comfortable state.

FLUCTUATION IN ATMOSPHERIC PRESSURE

1

2



MAGIC STYLE

Living Office
For the office
innovation trend



A1726-2



A1726-2



B1726-2



C1726-2

Advanced anti-static, soft texture details, first class breathability.



A1726-2



B1726-2



C1726-1



B1720-2

The design of the unique appearance is more appealing to charm of the product.

1

CONSTANTLY CREATE MORE FASHIONABLE AND AESTHETICALLY BEAUTIFUL OFFICE SPACE

ELEGANT FASHION

2



B1720-1

Technology

The electroplating process with an final polishes is durable, bright and healthy



Flexibility

The e...lating
proc...h no
fin...on is
dura...nt: and



A1708

In the overall practical design, the design of the opposite sex, even the stylized administrative office, has added a few interesting.



C1708



B1708

In the overall practical design, the design of the opposite sex, even the stylized administrative office, has added a few interesting.

外观独特的设计更添产品的魅力。

The design of the unique appearance is more appealing to charm of the product.

1

ELEGANT FASHION

优雅时尚

2



A1716



B1716

THE AESTHETIC FEELING

The lines are clear and simple, but the beauty curve of the concave and convex is superior to the human, and the flowery color can be used in the design of the heart process.



C1716



KA-01L

Hardware components with rough shapes and smooth texture have brought rich sense of potency to the simple office chairs. Relying on the strong plasticity of metal, it has realized highly difficult design dreams and crated high style artistic quality of modern and fashionable office space.



KA-02L



KA-03L



B1812



B1812

Closely the pulse of The Times, deduce fashion life, fusion modern office the latest popular element, innovative avant-garde open and have individual character, have a fashion brand new experience, comprehend the new refined taste of the modern office life



A1711



B1711



KA-01L



KA-01L



KA-02L



KA-03L

FOR THE UNFETTERED SOUL

Searching for a magic dazzle eye effect, simple and not simple, soft arc diastolic, freely flowing from the back of a chair to the edge of the seat cushion, every detail from the witness the highest pursuit of art and technique Furico New Look and style, full with charming glamour of new decoration with uncommon lasting appeal



A1801-1



B1801-1



C1801-1



THE EXQUISITE AND ELEGANT MODERN CHARM



A1711

EVOLUTION, MY OFFICE FORM

Get rid of static state, or sitting or leaving, discussing, tea-tasting, take a sip, and enjoy my office life!



B1711



C1711



A1819



C1819



B1819



C1819-0

The fine elaboration on the scale gives normal space unusual visual feeling, almost surprise aesthetic appeal, and endow office space with unique charm.

NEW CONCEPT



A1819



B1819

EXCELLENCE, HIGH GRADE



C1819



C1819-O



Material is the root of deciding the product quality, in order to make products more sturdy, the principle of the New Look is "put fine timber to petty use", using stainless steel building materials engineering, stand out in the 50 comparison of a variety of materials selection, material as the main body of the New Look Choose in fabrics on modern Nano polymer materials, antibacterial anti-ultraviolet, anti-aging performance, unique textile processing, has the stronger tensile resistance, guarantees the high elastic seat

Engineering square steel
The main body material of chair seat guarantees the unmatched solid quality of the seat.



A1815

FAIRYLAND, MOOD

Searching for a magic dazzle eye effect, subtle and not simple, soft and dynamic, lines following from the back of a chair to the edge of the seat cushion, every detail from the smallest to the highest passed to art and technique. Fairyland. New look and style, but with charming glamour of new decoration with uncommon lasting appeal.





A1806

Searching for a magic dazzle eye effect, simple and not simple, soft air diastolic, freely flowing from the back of a chair to the edge of the seat cushion, every detail from the witness the highest pursuit of art and technique Furico New Look and style, full with charming glamour of new decoration with uncommon lasting appeal



A1806

Brand Story

The fine elaboration on the scale gives normal space unusual visual feeling, almost surprise aesthetic appeal, and endow office space with unique charm.

Simple and avant-garde design, complex and repetitive details are removed, replaced by scientific mechanical support, with a pure and beautiful space structure, and elegant fashion furniture becomes the focus of vision.



A1801



B1801



C1801



A1801

Brand Story

The fine elaboration on the scale gives normal space unusual visual feeling, almost surprise aesthetic appeal, and endow office space with unique charm.

The fine elaboration on the scale gives normal space unusual visual feeling, almost surprise aesthetic appeal, and endow office space with unique charm.



A1801



B1801



C1801

Excellence

FASCINATED COMFORTABLE FEELING



Fairyland, mood

The fine elaboration on the scale gives normal space unusual visual feeling, almost surprise aesthetic appeal, and endow office space with unique charm.

New Look, driven by the trend of advanced science and technology, integrates the creative idea and multi-element culture of mankind, showing its own taste.



A1809



B1809



C1809

PROVOKE



Interview



Fascinated Feeling

FASCINATED COMFORTABLE FEELING



A1809-1



B1809-1



C1809-1



A1809-1



A1809-1



B1809-1



C1809-1

New Look

FASCINATED COMFORTABLE FEELING

New Look as an example the application of ergonomics, the new s-shaped chair design, make the backbone force is more uniform and reasonable, combined with the four joint support, further dispersing body pressure, regulating function of human nature, can be used in different forms under the regulation of follow one's inclinations, make people in the work life truly take rests

Material is the root of deciding the product quality, in order to make products more sturdy, the principle of the New Look is "put fine timber to petty use", using stainless steel building materials engineering, stand out in the so comparison of a variety of materials selection, material as the main body of the New Look Choose in fabrics on modern Nano polymer materials, antibacterial anti-ultraviolet, anti-aging performance, unique textile processing, has the stronger tensile resistance, guarantees the high elastic seat

ANY COLOR CHOSING





B1601



A1601



C1601



Male lines and high-quality ash overall framework make this series of chairs elegant and exquisite. They are individual but not self-asserted, calm and full of internal implication. There are four colors of surface for you to choose, which helps you to construct a fashionable and personal office space with individuality.



A1804

There is no magic in the world, but the reality is unable to bind our imagination of mysticism. By the combination of leather and metal, we use creativity to create magical beauty for chairs, give a little more imagination to life, and give more the joy of success rational office space.

Fashion magic and Industrial aesthetics, together create fashion aesthetic feeling.



B1804



C1804

New Collection



A1825



A1825



B1825



C1825

The clear color, the gentle line, in here temporarily forget the work, make the soul immerse in the plain simple color, get back the original appearance of the soul.



A1635-1

THE EXQUISITE AND ELEGANT MODERN CHARM



SIMPLE AND STYLISH

Elaborate design New Look, the arch backrest and armrest shows unique ingenuity and self-contained style, in strict accordance with the ergonomics design should provide the most comfortable retainer shape curve and the most powerful support



B1635-1



C1635-1

Modern

THE EXQUISITE AND ELEGANT MODERN CHARM



A1826

B1826

Leather

High quality leather

EXTREMELY RICH INTERNATIONAL FASHION SENSE



A1826



B1826



C1826

ourselves, and face the trend in the constant innovation and rebirth, and follow closely. When we design and emphasize the material, line is light of space, and it can be designed, be added the ideas of the element in the space, and when we have the visual nerve of sinking large metal feeling, modernism, and so on empty after cold stimulation, office, conference room, in the modern through traditional poetic complex, but at the bottom of consciousness gradually awaken



The fashion trend changes rapidly, and the house and home popular is changed with each passing day, in the time of respecting individuality and emphasizing self and everywhere choice, what is suitable perfect? After years of exploration and research, we constantly deny the past, challenge

CONSTANTLY CREATE MORE FASHIONABLE AND AESTHETICALLY BEAUTIFUL OFFICE SPACE



A1811

New Collection,



A1811



B1811

Use elegant curve to outline freely, make modelling more vigor more having level. Matched with the cool and proud electroplating metal chair foot and armrest, it builds more unique and more delicate office space.



Ucrasima et Idempus eve
THREE BILLBOAIDE EBBING, MISSOURI



A1811



B1811

New Look has been seeking the unique design, from the enlightenment the coming dream by art of Pompidou magic group to get the inspiration, to the armrest of distinctive products design and with movable wheel chair foot, all represents the company, illuminating design. New metal structure, as well as the back of the human body engineering and comfortable sexual function, is the tailored ideal products for the modern high class white-collar workers.

CONSCIOUSNESS OF A WORKER



A1605



B1605



C1605

FURICO office chair looks down on and up to stormy or unstable situations, and turns the blueprint of magnificent cause together with successors.



A1605



A1629-1



B1629-1



C1629-1

The breath of age for product can be reflected by mastering modern technology, technique, equipment and material, and applying the emotional design idea.



The brief and smooth line gives you the clean and pure visual perception. What I long for more seriously is simplicity when I return back to my private office space after looking over the colorful urban prosperity outside.



A1518



B1518

The design of the unique appearance is more appealing to charm of the product.

1

CONSTANTLY CREATE MORE FASHIONABLE AND AESTHETICALLY BEAUTIFUL OFFICE SPACE



F198



A1723

Distinguished fashion, display excellence

New Look has been seeking the unique design, from the enlightenment the coming dream by art of Pompidou magic group to get the inspiration, to the utmost of distinctive products design and with movable wheel chair foot, all represents the company, illuminating design New metal structure, as well as the back of the human body engineering and comfortable sexual function, is the tailored ideal products for the modern high class white-collar workers.



F208



F308



B1723



C1723

With the light wind and light floating cloud attitude,
walk in your world!

Color World

The unique material combination, pure and fresh color is color matching, everything is the revealing of clever mind and show infinite modern aesthetic feeling.

独特的材质组合，清新的色彩搭配，一切都是巧妙心思的流露，展现无限现代美感。



A1701



A1701



A1701



B1701



A1813



B1813



C1813

FASHION ATTITUDE

Constantly create more fashionable and aesthetically beautiful office space.

6



A1802



B1802



C1802







FK003-F



FK003-A



FK003-B





FK004-A13



FK004-A11



FK004-B12



FK004-A11



FK004-B11



FK004-C11



FK004-A12



FK004-B12



FK004-C12



FK004-A12



FK004-B12



FK004-C12



FK005-A



FK005-B



FK005-C





A2112



B2112



C2112



A2112



B2112



C2112



A2069-1



B2069-1



C2069-1



A2019



B2019



C2019



A2019



B2019



C2019



C2001



B2001



B2011



C2011-1



C2011-2



F2016





A2119



B2119



C2119



A2067



B2067



C2067



A2108



B2108



C2108



A2018



B2018



C2018





A2160



B2160



C2160



A2106



B2106



C2106



C2116



B2116



A2116



A1811-1



B1811-1







FK006-A



FK006-A



FK006-B



FK006-B

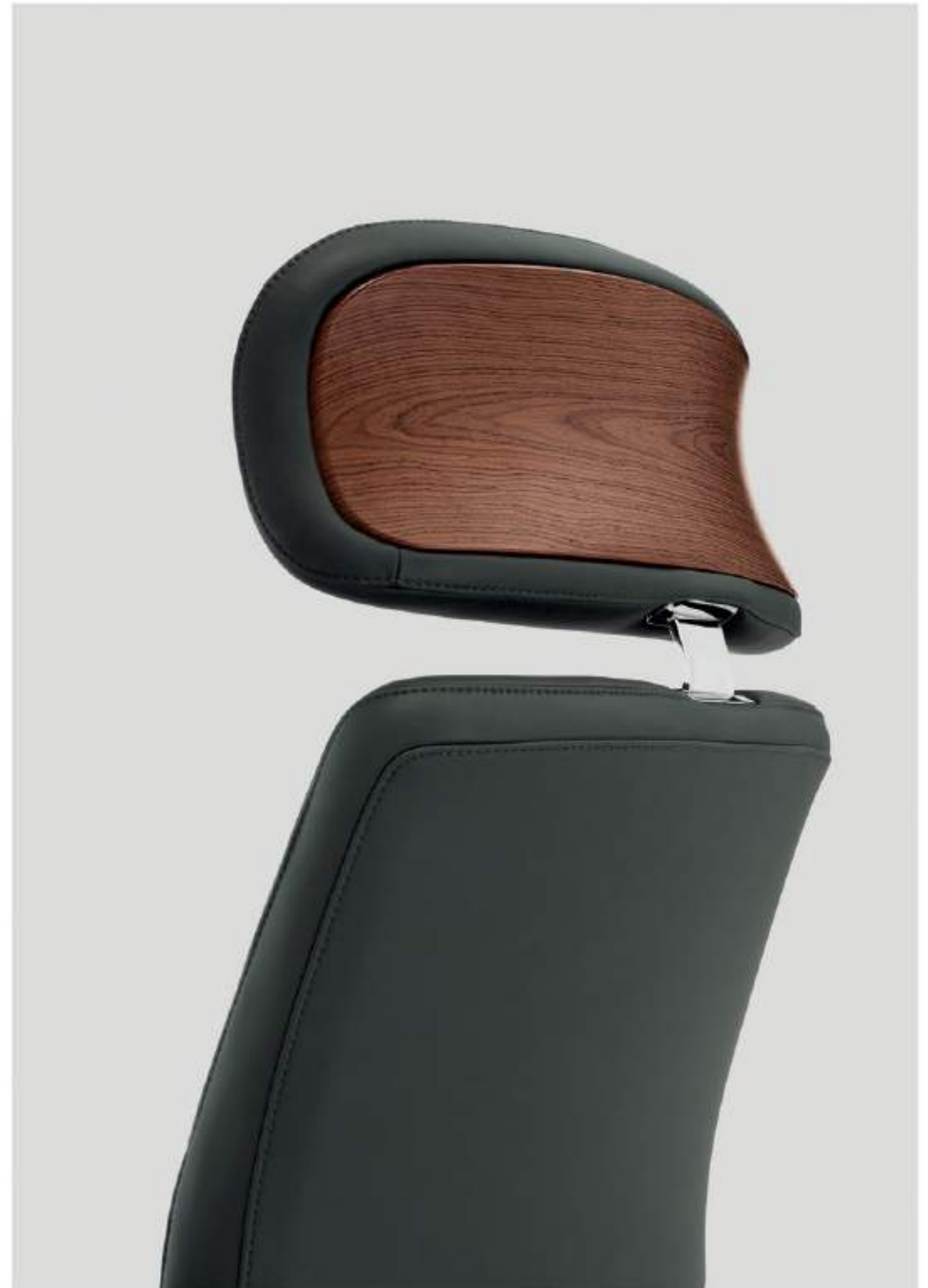







FK003-F-1



FK003-F-1



FK003-F-1



FK003-F-1







FK007-B11



FK007-B11



FK007-C12



FK007-B12





A2219



B2219



C2219





A2218



B2218



C2218





A2218



B2218



C2218



A2206



B2206



C2206





A2206



B2206



B2206





A2216



B2216



C2216





A2208



B2208



C2208





A2208



B2208



C2208



A2262



B2262



C2262





A2262



B2262



C2262







F2205



T2205



Executive Desk







BTCG-2 Model



BTCG-3 Model



BTCG-3 Model





BTCG-6 Model



BTCG-7 Model



BTCG-16 Model



BTCG-17 Model







BTCG-38 Model





BTCG-41 Model



BTCG-43 Model



BTCG-44 Model



BTCG-48 Model



BTCG-49 Model



BTCG-50 Model





BTCG-57 Model



BTCG-60 Model



BTCG-61 Model







BTCG-88 Model







BTCG-91 Model



BTCG-9 Model



BT CG-13 Model



BTCG-14 Model



BTCG-15 Model



BTCG-12 Model





BTCG-58 Model







BTCG-74 Model



BTCG-92 Model





Classical style CEO desk





BTCG-23 Model



BTCG-22 Model



BTCG-24 Model



BTCG-25 Model



BTCG-26 Model



BTCG-27 Model



BTCG-29 Model



BTCG-31 Model



BTCG-30 Model



BTCG-28 Model



BTCG-33 Model



BTCG-32 Model



BTCG-32 Model



Conference table



HYCG-1 Model









HYCG-5 Model





HYCG-10 Model



HYCG-11 Model





HYCG-12 Model





HYCG-19 Model





HYCG-22 Model



HYCG-47 Model



HYCG-54 Model



HYCG-55 Model



HYCG-56 Model



HYCG-61 Model





HYCG-14 Model



HYCG-15 Model



HYCG-16 Model





HYCG-44 Model



HYCG-46 Model



HYCG-48 Model



HYCG-58 Model



HYCG-57 Model



HYCG-52 Model



HYCG-51 Model





HYCG-53 Model



Reception Desk









QTCG-3 Model



QTCG-5 Model





QTCG-7 Model



INT
LONG YU INTERNATIONALS















QTCG-17 Model







MEIYOUONG
美妍医疗美容









QTCG-29 Model





QTCG-31 Model



QTCG-52 Model



**AOREI
CONSULTING**





RONGMAN
戒漫家具旗舰店













Staff Desk





ZYCG-2 Model









ZYCG-5 Model









ZYCG-15 Model





ZYCG-21 Model









ZYCG-22 Model



ZYCG-29 Model



ZYCG-30 Model







ZYCG-43 Model









OFFICE SOFA













































SFCG-25 Model



SFCG-29 Model





SFCG-29 Model



BTCG-1 Model

Features:

1. With four vertical plates---more stable and firm.
2. Thickened desktop
3. The side cabinet with pulley can move freely
4. Healthy and environment-friendly board, fireproof, scratch proof and moisture-proof
5. The side cabinet can be selected from left to right, with PVC and aluminum alloy edging

Colors:Model oak/colour customized

Size		
W1600*D700*H750 (5.24*2.62*2.46Feet)	W1800*D800*H750(5.9*2.62*2.46Feet)	W2000*D800*H750(6.56*2.62*2.46Feet)
W2200*D800*H750(7.21*2.62*2.46Feet)	W2400*D800*H750(7.87*2.65*2.46feet)	W2600*D900*H750(8.53*2.95*2.46feet)
W2800*D900*H750(9.18*2.95*2.46feet)	W3000*D900*H750(9.84*2.95*2.46feet)	Customized



BTCG-2 Model

Features:

1. High quality aluminum alloy steel foot support, more stable.
2. Thickened 2.5cm desktop, large space and more storage
3. Marble pattern, strong and durable
4. Health and environmental E1 board, fireproof, scratch proof, moisture-proof and durable
5. The side cabinet can be selected from left to right, with PVC and aluminum alloy edge sealing

Colors:Model oak/colour customized

Size		
W1600*D700*H750 (5.24*2.62*2.46Feet)	W1800*D800*H750(5.9*2.62*2.46Feet)	W2000*D800*H750(6.56*2.62*2.46Feet)
W2200*D800*H750(7.21*2.62*2.46Feet)	W2400*D800*H750(7.87*2.65*2.46feet)	W2600*D900*H750(8.53*2.95*2.46feet)
W2800*D900*H750(9.18*2.95*2.46feet)	W3000*D900*H750(9.84*2.95*2.46feet)	Customized





BTCG-3 Model

Features:

1. High quality aluminum alloy steel foot support, more stable.
2. Thickened 2.5cm desktop, large space and more storage
3. Marble pattern, strong and durable
4. Health and environmental protection board E1 board, fireproof, scratch proof, moisture-proof and durable
5. The side cabinet can be selected from left to right, with PVC and aluminum alloy edge sealing

Colors:white/colour customized



Size		
W1600*D800*H750 (5.24*2.62*2.46Feet)	W1800*D800*H750(5.9*2.62*2.46Feet)	W2000*D800*H750(6.56*2.62*2.46Feet)
W2200*D800*H750(7.21*2.62*2.46Feet)	W2400*D800*H750(7.87*2.65*2.46feet)	Customized

BTCG-3 Model

Features:

1. Thickened 5cm desktop, large space and more storage
2. Marble pattern, strong and durable
3. Health and environmental E1 board, fireproof, scratch proof, moisture-proof and durable
4. The side cabinet can be selected from left to right, with PVC and aluminum alloy edge sealing

Colors:Model oak/colour customized



Gold oak



Teak color



Model oak

Size		
W1600*D700*H750 (5.24*2.62*2.46Feet)	W1800*D800*H750(5.9*2.62*2.46Feet)	W2000*D800*H750(6.56*2.62*2.46Feet)
W2200*D800*H750(7.21*2.62*2.46Feet)	W2400*D800*H750(7.87*2.65*2.46feet)	W2600*D900*H750(8.53*2.95*2.46feet)
W2800*D900*H750(9.18*2.95*2.46feet)	W3000*D900*H750(9.84*2.95*2.46feet)	Customized



BTCG-5 Model

Features:

1. 5cm thick desktop, large space and storage space
2. Marble pattern, firm and durable
3. Health and environmental protection board E1 board, fireproof, scratch proof, moisture-proof and durable
4. The side cabinet can be selected from left to right, using PVC and aluminum alloy lines

Colors:white/colour customized



Size		
W1600*D700*H750 (5.24*2.62*2.46Feet)	W1800*D800*H750(5.9*2.62*2.46Feet)	W2000*D800*H750(6.56*2.62*2.46Feet)
W2200*D800*H750(7.21*2.62*2.46Feet)	W2400*D800*H750(7.87*2.65*2.46feet)	W2600*D900*H750(8.53*2.95*2.46feet)
W2800*D900*H750(9.18*2.95*2.46feet)	W3000*D900*H750(9.84*2.95*2.46feet)	Customized



BTCG-6 Model

Features:

1. 5cm thick desktop, large space and storage space
2. Marble pattern, firm and durable
3. Health and environmental protection board E1 board, fireproof, scratch proof, moisture-proof and durable
4. The side cabinet can be selected from left to right, and PVC fine edge sealing is used

Colors:white/colour customized

Size		
W1600*D700*H750 (5.24*2.62*2.46Feet)	W1800*D800*H750(5.9*2.62*2.46Feet)	W2000*D800*H750(6.56*2.62*2.46Feet)
W2200*D800*H750(7.21*2.62*2.46Feet)	W2400*D800*H750(7.87*2.65*2.46feet)	W2600*D900*H750(8.53*2.95*2.46feet)
W2800*D900*H750(9.18*2.95*2.46feet)	W3000*D900*H750(9.84*2.95*2.46feet)	Customized

White marble + model oak White marble + teak

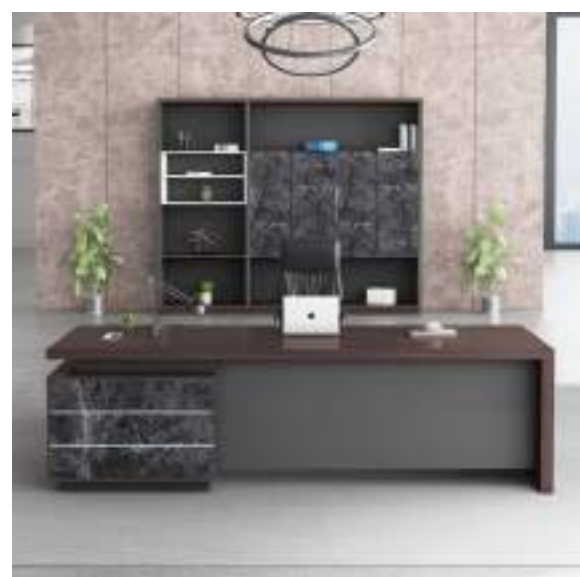

Black marble + model oak

BTCG-7 Model



White marble + model oak White marble + gold oak

Features:

1. 5cm thick desktop, large space and storage space
2. Marble pattern, firm and durable
3. Health and environmental protection board E1 board, fireproof, scratch proof, moisture-proof and durable
4. The side cabinet can be selected from left to right, using PVC and aluminum alloy wire boxes can be selected from left to right, using PVC and aluminum alloy lines

Colors: white/colour customized

Size		
W1600*D700*H750 (5.24*2.62*2.46Feet)	W1800*D800*H750(5.9*2.62*2.46Feet)	W2000*D800*H750(6.56*2.62*2.46Feet)
W2200*D800*H750(7.21*2.62*2.46Feet)	W2400*D800*H750(7.87*2.65*2.46feet)	W2600*D900*H750(8.53*2.95*2.46feet)
W2800*D900*H750(9.18*2.95*2.46feet)	W3000*D900*H750(9.84*2.95*2.46feet)	Customized

BTCG-16 Model

Features:

1. High quality aluminum alloy steel foot support, more stable.
2. Thickened 2.5cm desktop, large space and more storage
3. Marble pattern, strong and durable
4. Health and environmental protection board E1 board, fireproof, scratch proof, moisture-proof and durable
5. The side cabinet can be selected from left to right, with PVC and aluminum alloy edge sealing

Colors: white/colour customized



Classic black and white



Gold oak + Pearl White



Teak + iron grey

Size		
W1600*D700*H750 (5.24*2.62*2.46Feet)	W1800*D800*H750(5.9*2.62*2.46Feet)	W2000*D800*H750(6.56*2.62*2.46Feet)
W2200*D800*H750(7.21*2.62*2.46Feet)	W2400*D800*H750(7.87*2.65*2.46feet)	Customized



BTCG-17 Model

Features:

- 1. High quality aluminum alloy artistic steel tripod
- 2. Thickened desktop with large space and storage space
- 3. Health and environmental protection board E1 board, fireproof, scratch proof, moisture-proof and durable
- 4. The side cabinet can be selected from left to right, using PVC and aluminum alloy wire boxes

Colors:white/colour customized

Size		
W1600*D700*H750 (5.24*2.62*2.46Feet)	W1800*D800*H750(5.9*2.62*2.46Feet)	W2000*D800*H750(6.56*2.62*2.46Feet)
W2200*D800*H750(7.21*2.62*2.46Feet)	W2400*D800*H750(7.87*2.65*2.46feet)	Customized

BTCG-34 Model

Features:

- 1. 5cm thick desktop, large space and storage space
- 2. Health and environmental protection board E1 board, fireproof, scratch proof, moisture-proof and durable
- 3. The side cabinet can be selected from left to right, using PVC and aluminum alloy wire box
- 4 Baking paint inclined feet, more firm, self-service radiator

Colors:white/colour customized

Size		
W1600*D700*H750 (5.24*2.62*2.46Feet)	W1800*D800*H750(5.9*2.62*2.46Feet)	W2000*D800*H750(6.56*2.62*2.46Feet)
W2200*D800*H750(7.21*2.62*2.46Feet)	W2400*D800*H750(7.87*2.65*2.46feet)	W2600*D900*H750(8.53*2.95*2.46feet)
W2800*D900*H750(9.18*2.95*2.46feet)	W3000*D900*H750(9.84*2.95*2.46feet)	Customized





BTCG-35 Model

Features:

- 1. 5cm thick desktop, large space and storage space
- 2. Health and environmental protection board E1 board, fireproof, scratch proof, moisture-proof and durable
- 3. The side cabinet can be selected from left to right, using PVC and aluminum alloy wire boxes
- 4. Hand carved, self-service radiator

Colors:Teak color/colour customized

Size		
W1600*D700*H750 (5.24*2.62*2.46Feet)	W1800*D800*H750(5.9*2.62*2.46Feet)	W2000*D800*H750(6.56*2.62*2.46Feet)
W2200*D800*H750(7.21*2.62*2.46Feet)	W2400*D800*H750(7.87*2.65*2.46feet)	W2600*D900*H750(8.53*2.95*2.46feet)
W2800*D900*H750(9.18*2.95*2.46feet)	W3000*D900*H750(9.84*2.95*2.46feet)	Customized

BTCG-38 Model

Features:

- 1. High quality aluminum alloy artistic steel foot
- 2. Thickened desktop, large space and storage space
- 3. Health and environmental protection board E1 board, fireproof, scratch proof, moisture-proof and durable
- 4. The side cabinet can be selected from left to right, using PVC and aluminum alloy wire boxes

Colors:white/colour customized

Size		
W1600*D700*H750 (5.24*2.62*2.46Feet)	W1800*D800*H750(5.9*2.62*2.46Feet)	W2000*D800*H750(6.56*2.62*2.46Feet)
W2200*D800*H750(7.21*2.62*2.46Feet)	W2400*D800*H750(7.87*2.65*2.46feet)	Customized



Gold oak



Teak color



Pearl White



Classice oak



BTCG-39 Model

Features:

- 1. 1.5cm thick desktop, large space and storage space
- 2. Health and environmental protection board E1 board, fireproof, scratch proof, moisture-proof and durable
- 3. The side cabinet can be selected from left to right, using PVC and aluminum alloy wire boxes
- 4. Luxury double-sided cabinet, firmer, self-service radiator
- 5. Black marble



Colors:white/colour customized

Size		
W1600*D700*H750 (5.24*2.62*2.46Feet)	W1800*D800*H750(5.9*2.62*2.46Feet)	W2000*D800*H750(6.56*2.62*2.46Feet)
W2200*D800*H750(7.21*2.62*2.46Feet)	W2400*D800*H750(7.87*2.65*2.46feet)	W2600*D900*H750(8.53*2.95*2.46feet)
W2800*D900*H750(9.18*2.95*2.46feet)	W3000*D900*H750(9.84*2.95*2.46feet)	Customized



BTCG-41 Model

Features:

- 1. 1.5cm thick desktop, large space and storage space
- 2. Health and environmental protection board E1 board, fireproof, scratch proof, moisture-proof and durable
- 3. The side cabinet can be selected from left to right, using PVC and aluminum alloy wire boxes
- 4. Self service radiator
- 5. Hand carved patterns



Colors:white/colour customized

Size		
W1600*D700*H750 (5.24*2.62*2.46Feet)	W1800*D800*H750(5.9*2.62*2.46Feet)	W2000*D800*H750(6.56*2.62*2.46Feet)
W2200*D800*H750(7.21*2.62*2.46Feet)	W2400*D800*H750(7.87*2.65*2.46feet)	W2600*D900*H750(8.53*2.95*2.46feet)
W2800*D900*H750(9.18*2.95*2.46feet)	W3000*D900*H750(9.84*2.95*2.46feet)	Customized



BTCG-43 Model

Features:

- 1. 1.5cm thick desktop, large space and storage space
- 2. Health and environmental protection board E1 board, fireproof, scratch proof, moisture-proof and durable
- 3. The side cabinet can be selected from left to right, using PVC and aluminum alloy wire boxes
- 4. Self service radiator, luxury double side cabinet

Colors:white/colour customized

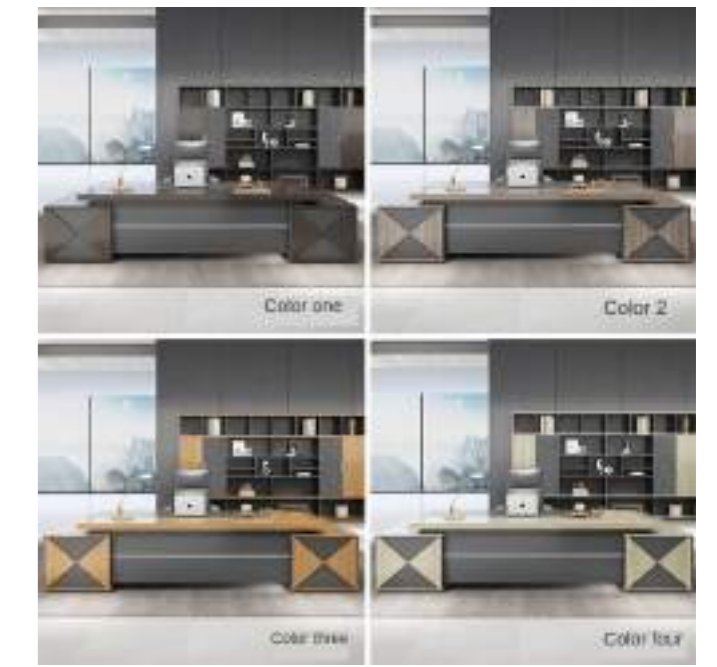

Size		
W1600*D700*H750 (5.24*2.62*2.46Feet)	W1800*D800*H750(5.9*2.62*2.46Feet)	W2000*D800*H750(6.56*2.62*2.46Feet)
W2200*D800*H750(7.21*2.62*2.46Feet)	W2400*D800*H750(7.87*2.65*2.46feet)	W2600*D900*H750(8.53*2.95*2.46feet)
W2800*D900*H750(9.18*2.95*2.46feet)	W3000*D900*H750(9.84*2.95*2.46feet)	Customized



BTCG-44 Model

Features:

- 1. 5cm thick desktop, large space and storage space
- 2. Health and environmental protection board E1 board, fireproof, scratch proof, moisture-proof and durable
- 3. The side cabinet can be selected from left to right, using PVC and aluminum alloy wire boxes
- 4. Self service radiator, luxury double side cabinet

Colors:white/colour customized



Size		
W1600*D700*H750 (5.24*2.62*2.46Feet)	W1800*D800*H750(5.9*2.62*2.46Feet)	W2000*D800*H750(6.56*2.62*2.46Feet)
W2200*D800*H750(7.21*2.62*2.46Feet)	W2400*D800*H750(7.87*2.65*2.46feet)	W2600*D900*H750(8.53*2.95*2.46feet)
W2800*D900*H750(9.18*2.95*2.46feet)	W3000*D900*H750(9.84*2.95*2.46feet)	Customized



BTCG-48 Model

Features:

1. High quality aluminum alloy artistic steel foot
2. Thickened desktop, large space and storage space
3. Health and environmental protection board E1 board, fireproof, scratch proof, moisture-proof and durable
4. The side cabinet can be selected from left to right, using PVC and aluminum alloy wire boxes

Colors:white/colour customized

Size		
W1600*D700*H750 (5.24*2.62*2.46Feet)	W1800*D800*H750(5.9*2.62*2.46Feet)	W2000*D800*H750(6.56*2.62*2.46Feet)
W2200*D800*H750(7.21*2.62*2.46Feet)	W2400*D800*H750(7.87*2.65*2.46feet)	Customized

BTCG-49 Model

Features:

1. 5cm thick desktop, large space and storage space
2. Health and environmental protection board E1 board, fireproof, scratch proof, moisture-proof and durable
3. The side cabinet can be selected from left to right, using PVC and aluminum alloy wire boxes
4. Self service radiator, luxury double side cabinet

Colors:white/colour customized

Size		
W1600*D700*H750 (5.24*2.62*2.46Feet)	W1800*D800*H750(5.9*2.62*2.46Feet)	W2000*D800*H750(6.56*2.62*2.46Feet)
W2200*D800*H750(7.21*2.62*2.46Feet)	W2400*D800*H750(7.87*2.65*2.46feet)	W2600*D900*H750(8.53*2.95*2.46feet)
W2800*D900*H750(9.18*2.95*2.46feet)	W3000*D900*H750(9.84*2.95*2.46feet)	Customized





BTCG-50 Model

Features:

1. High quality aluminum alloy artistic steel foot
2. Thickened desktop, large space and storage space
3. Health and environmental protection board E1 board, fireproof, scratch proof, moisture-proof and durable
4. The side cabinet can be selected from left to right, using PVC and aluminum alloy wire boxes

Colors:white/colour customized



Size		
W1600*D700*H750 (5.24*2.62*2.46Feet)	W1800*D800*H750(5.9*2.62*2.46Feet)	W2000*D800*H750(6.56*2.62*2.46Feet)
W2200*D800*H750(7.21*2.62*2.46Feet)	W2400*D800*H750(7.87*2.65*2.46feet)	Customized

BTCG-51 Model

Features:

1. 5cm thick desktop, large space and storage space
2. Health and environmental protection board E1 board, fireproof, scratch proof, moisture-proof and durable
3. The side cabinet can be selected from left to right, using PVC and aluminum alloy wire boxes
4. Self service radiator, luxury double side cabinet

Colors:white/colour customized



Size		
W1600*D700*H750 (5.24*2.62*2.46Feet)	W1800*D800*H750(5.9*2.62*2.46Feet)	W2000*D800*H750(6.56*2.62*2.46Feet)
W2200*D800*H750(7.21*2.62*2.46Feet)	W2400*D800*H750(7.87*2.65*2.46feet)	W2600*D900*H750(8.53*2.95*2.46feet)
W2800*D900*H750(9.18*2.95*2.46feet)	W3000*D900*H750(9.84*2.95*2.46feet)	Customized



BTCG-57 Model

Features:

1. 5cm thick desktop, large space and storage space
2. Health and environmental protection board E1 board, fireproof, scratch proof, moisture-proof and durable
3. The side cabinet can be selected from left to right, using PVC and aluminum alloy wire boxes
4. Self service radiator, luxury double side cabinet

Colors:white/colour customized

Size		
W1600*D700*H750 (5.24*2.62*2.46Feet)	W1800*D800*H750(5.9*2.62*2.46Feet)	W2000*D800*H750(6.56*2.62*2.46Feet)
W2200*D800*H750(7.21*2.62*2.46Feet)	W2400*D800*H750(7.87*2.65*2.46feet)	W2600*D900*H750(8.53*2.95*2.46feet)
W2800*D900*H750(9.18*2.95*2.46feet)	W3000*D900*H750(9.84*2.95*2.46feet)	Customized



BTCG-60 Model

Features:

- 1.5cm thick desktop, large space and storage space
2. Health and environmental protection board E1 board, fireproof, scratch proof, moisture-proof and durable
3. The side cabinet can be selected from left to right, using PVC and aluminum alloy wire boxes
4. Simple modern environmental protection style

Colors:white/colour customized



Size		
W1600*D700*H750 (5.24*2.62*2.46Feet)	W1800*D800*H750(5.9*2.62*2.46Feet)	W2000*D800*H750(6.56*2.62*2.46Feet)
W2200*D800*H750(7.21*2.62*2.46Feet)	W2400*D800*H750(7.87*2.65*2.46feet)	W2600*D900*H750(8.53*2.95*2.46feet)
W2800*D900*H750(9.18*2.95*2.46feet)	W3000*D900*H750(9.84*2.95*2.46feet)	Customized

BTCG-61 Model

Features:

1. 5cm thick desktop, large space and storage space
2. Health and environmental protection board E1 board, fireproof, scratch proof, moisture-proof and durable
3. The side cabinet can be selected from left to right, using PVC and aluminum alloy wire boxes
4. Simple modern environmental protection style

Colors:white/colour customized



Size		
W1600*D700*H750 (5.24*2.62*2.46Feet)	W1800*D800*H750(5.9*2.62*2.46Feet)	W2000*D800*H750(6.56*2.62*2.46Feet)
W2200*D800*H750(7.21*2.62*2.46Feet)	W2400*D800*H750(7.87*2.65*2.46feet)	W2600*D900*H750(8.53*2.95*2.46feet)
W2800*D900*H750(9.18*2.95*2.46feet)	W3000*D900*H750(9.84*2.95*2.46feet)	Customized

BTCG-85 Model

Features:

- 1.5cm thick desktop, large space and storage space
2. Health and environmental protection board E1 board, fireproof, scratch proof, moisture-proof and durable
3. The side cabinet can be selected from left to right, using PVC and aluminum alloy wire boxes
4. Modern light luxury style

Colors:white/colour customized



Size		
W1600*D700*H750 (5.24*2.62*2.46Feet)	W1800*D800*H750(5.9*2.62*2.46Feet)	W2000*D800*H750(6.56*2.62*2.46Feet)
W2200*D800*H750(7.21*2.62*2.46Feet)	W2400*D800*H750(7.87*2.65*2.46feet)	W2600*D900*H750(8.53*2.95*2.46feet)
W2800*D900*H750(9.18*2.95*2.46feet)	W3000*D900*H750(9.84*2.95*2.46feet)	Customized





BTCG-86 Model

Features:

- 1. 1.5cm thick desktop, large space and storage space
- 2. Health and environmental protection board E1 board, fireproof, scratch proof, moisture-proof and durable
- 3. The side cabinet can be selected from left to right, using PVC and aluminum alloy wire boxes
- 4. Modern light luxury style

Colors:white/colour customized

Size		
W1600*D700*H750 (5.24*2.62*2.46Feet)	W1800*D800*H750(5.9*2.62*2.46Feet)	W2000*D800*H750(6.56*2.62*2.46Feet)
W2200*D800*H750(7.21*2.62*2.46Feet)	W2400*D800*H750(7.87*2.65*2.46feet)	W2600*D900*H750(8.53*2.95*2.46feet)
W2800*D900*H750(9.18*2.95*2.46feet)	W3000*D900*H750(9.84*2.95*2.46feet)	Customized

BTCG-88 Model

Features:

- 1. 1.5cm thick desktop, large space and storage space
- 2. Health and environmental protection board E1 board, fireproof, scratch proof, moisture-proof and durable
- 3. The side cabinet can be selected from left to right, using PVC and aluminum alloy wire boxes
- 4. Modern light luxury style---Tesla

Colors:white/colour customized

Size		
W1600*D700*H750 (5.24*2.62*2.46Feet)	W1800*D800*H750(5.9*2.62*2.46Feet)	W2000*D800*H750(6.56*2.62*2.46Feet)
W2200*D800*H750(7.21*2.62*2.46Feet)	W2400*D800*H750(7.87*2.65*2.46feet)	W2600*D900*H750(8.53*2.95*2.46feet)
W2800*D900*H750(9.18*2.95*2.46feet)	W3000*D900*H750(9.84*2.95*2.46feet)	Customized





BTCG-89 Model

Features:

- 1. High quality aluminum alloy artistic steel foot
- 2. Thickened desktop, large space and storage space
- 3. Health and environmental protection board E1 board, fireproof, scratch proof, moisture-proof and durable
- 4. The side cabinet can be selected from left to right, using PVC and aluminum alloy wire boxes

Colors:white/colour customized

Size		
W1600*D700*H750 (5.24*2.62*2.46Feet)	W1800*D800*H750(5.9*2.62*2.46Feet)	W2000*D800*H750(6.56*2.62*2.46Feet)
W2200*D800*H750(7.21*2.62*2.46Feet)	W2400*D800*H750(7.87*2.65*2.46feet)	Customized

BTCG-90 Model

Features:

- 1. 5cm thick desktop, large space and storage space
- 2. Health and environmental protection board E1 board, fireproof, scratch proof, moisture-proof and durable
- 3. The side cabinet can be selected from left to right, using PVC and aluminum alloy wire boxes
- 4. Self service radiator, luxury double side cabinet

Colors:white/colour customized

Size		
W1600*D700*H750 (5.24*2.62*2.46Feet)	W1800*D800*H750(5.9*2.62*2.46Feet)	W2000*D800*H750(6.56*2.62*2.46Feet)
W2200*D800*H750(7.21*2.62*2.46Feet)	W2400*D800*H750(7.87*2.65*2.46feet)	W2600*D900*H750(8.53*2.95*2.46feet)
W2800*D900*H750(9.18*2.95*2.46feet)	W3000*D900*H750(9.84*2.95*2.46feet)	Customized



BTCG-91 Model

Features:

1. 5cm thick desktop, large space and storage space
2. Health and environmental protection board E1 board, fireproof, scratch proof, moisture-proof and durable
3. The side cabinet can be selected from left to right, using PVC and aluminum alloy wire boxes
4. Simple modern environmental protection style

Colors:white/colour customized



Size		
W1600*D700*H750 (5.24*2.62*2.46Feet)	W1800*D800*H750(5.9*2.62*2.46Feet)	W2000*D800*H750(6.56*2.62*2.46Feet)
W2200*D800*H750(7.21*2.62*2.46Feet)	W2400*D800*H750(7.87*2.65*2.46feet)	W2600*D900*H750(8.53*2.95*2.46feet)
W2800*D900*H750(9.18*2.95*2.46feet)	W3000*D900*H750(9.84*2.95*2.46feet)	Customized

Paint baking CEO table Series



BTCG-8 Model

Features:

- 1.5cm thick desktop, large space and storage space
- Health and environmental protection board E1 density board, fireproof, scratch proof, moisture-proof, durable and easy to clean
- The side cabinet can be selected from left to right,
- Piano baking paint, bright, eight coat paint process

Colors:white/colour customized

Size		
W1600*D800*H750 (5.24*2.62*2.46Feet)	W1800*D800*H750(5.9*2.62*2.46Feet)	W2000*D800*H750(6.56*2.62*2.46Feet)
W2200*D800*H750(7.21*2.62*2.46Feet)	W2400*D800*H750(7.87*2.65*2.46feet)	W2600*D900*H750(8.53*2.95*2.46feet)
W2800*D900*H750(9.18*2.95*2.46feet)	W3000*D900*H750(9.84*2.95*2.46feet)	Customized

Features:

BTCG-9 Model

- 1.5cm thick desktop, sloping feet, large space and storage space
- Health and environmental protection board E1 density board, fireproof, scratch proof, moisture-proof, durable and easy to clean
- The side cabinet can be selected from left to right,
- Piano baking paint, bright, eight coat paint process

Colors:white/colour customized



Size		
W1600*D800*H750 (5.24*2.62*2.46Feet)	W1800*D800*H750(5.9*2.62*2.46Feet)	W2000*D800*H750(6.56*2.62*2.46Feet)
W2200*D800*H750(7.21*2.62*2.46Feet)	W2400*D800*H750(7.87*2.65*2.46feet)	W2600*D900*H750(8.53*2.95*2.46feet)
W2800*D900*H750(9.18*2.95*2.46feet)	W3000*D900*H750(9.84*2.95*2.46feet)	Customized



BTCG-10 Model

Features:

- 1. 1.5cm thick desktop, large space and storage space
- 2. Health and environmental protection board E1 density board, fireproof, scratch proof, moisture-proof, durable and easy to clean
- 3. The side cabinet can be selected from left to right,
- 4. Piano baking paint, bright, eight coat paint process

Colors:white/colour customized

Size		
W1600*D800*H750 (5.24*2.62*2.46Feet)	W1800*D800*H750(5.9*2.62*2.46Feet)	W2000*D800*H750(6.56*2.62*2.46Feet)
W2200*D800*H750(7.21*2.62*2.46Feet)	W2400*D800*H750(7.87*2.65*2.46feet)	W2600*D900*H750(8.53*2.95*2.46feet)
W2800*D900*H750(9.18*2.95*2.46feet)	W3000*D900*H750(9.84*2.95*2.46feet)	Customized



BTCG-11 Model

Features:

- 1. 1.5cm thick desktop, sloping feet, large space and storage space
- 2. Health and environmental protection board E1 density board, fireproof, scratch proof, moisture-proof, durable and easy to clean
- 3. The side cabinet can be selected from left to right,
- 4. Piano baking paint, bright, eight coat paint process

Colors:white/colour customized



Size		
W1600*D800*H750 (5.24*2.62*2.46Feet)	W1800*D800*H750(5.9*2.62*2.46Feet)	W2000*D800*H750(6.56*2.62*2.46Feet)
W2200*D800*H750(7.21*2.62*2.46Feet)	W2400*D800*H750(7.87*2.65*2.46feet)	W2600*D900*H750(8.53*2.95*2.46feet)
W2800*D900*H750(9.18*2.95*2.46feet)	W3000*D900*H750(9.84*2.95*2.46feet)	Customized

BTCG-12 Model



Features:

- 1. 1.5cm thick desktop, large space and storage space
- 2. Health and environmental protection board E1 density board, fireproof, scratch proof, moisture-proof, durable and easy to clean
- 3. The side cabinet can be selected from left to right,
- 4. Piano baking paint, bright, eight coat paint process

Colors:white/colour customized



Size		
W1600*D800*H750 (5.24*2.62*2.46Feet)	W1800*D800*H750(5.9*2.62*2.46Feet)	W2000*D800*H750(6.56*2.62*2.46Feet)
W2200*D800*H750(7.21*2.62*2.46Feet)	W2400*D800*H750(7.87*2.65*2.46feet)	W2600*D900*H750(8.53*2.95*2.46feet)
W2800*D900*H750(9.18*2.95*2.46feet)	W3000*D900*H750(9.84*2.95*2.46feet)	Customized

BTCG-13 Model

Features:

- 1. 1.5cm thick desktop, sloping feet, large space and storage space
- 2. Health and environmental protection board E1 density board, fireproof, scratch proof, moisture-proof, durable and easy to clean
- 3. The side cabinet can be selected from left to right,
- 4. Piano baking paint, bright, eight coat paint process

Colors:white/colour customized



Size		
W1600*D800*H750 (5.24*2.62*2.46Feet)	W1800*D800*H750(5.9*2.62*2.46Feet)	W2000*D800*H750(6.56*2.62*2.46Feet)
W2200*D800*H750(7.21*2.62*2.46Feet)	W2400*D800*H750(7.87*2.65*2.46feet)	W2600*D900*H750(8.53*2.95*2.46feet)
W2800*D900*H750(9.18*2.95*2.46feet)	W3000*D900*H750(9.84*2.95*2.46feet)	Customized



BTCG-14 Model

Features:

- 1. 1.5cm thick desktop, large space and storage space
- 2. Health and environmental protection board E1 density board, fireproof, scratch proof, moisture-proof, durable and easy to clean
- 3. The side cabinet can be selected from left to right,
- 4. Piano baking paint, bright, eight coat paint process

Colors:white/colour customized

Size		
W1600*D800*H750 (5.24*2.62*2.46Feet)	W1800*D800*H750(5.9*2.62*2.46Feet)	W2000*D800*H750(6.56*2.62*2.46Feet)
W2200*D800*H750(7.21*2.62*2.46Feet)	W2400*D800*H750(7.87*2.65*2.46feet)	W2600*D900*H750(8.53*2.95*2.46feet)
W2800*D900*H750(9.18*2.95*2.46feet)	W3000*D900*H750(9.84*2.95*2.46feet)	Customized

BTCG-15Model

Features:

- 1. 1.5cm thick desktop, sloping feet, large space and storage space
- 2. Health and environmental protection board E1 density board, fireproof, scratch proof, moisture-proof, durable and easy to clean
- 3. The side cabinet can be selected from left to right,
- 4. Piano baking paint, bright, eight coat paint process

Colors:white/colour customized

Size		
W1600*D800*H750 (5.24*2.62*2.46Feet)	W1800*D800*H750(5.9*2.62*2.46Feet)	W2000*D800*H750(6.56*2.62*2.46Feet)
W2200*D800*H750(7.21*2.62*2.46Feet)	W2400*D800*H750(7.87*2.65*2.46feet)	W2600*D900*H750(8.53*2.95*2.46feet)
W2800*D900*H750(9.18*2.95*2.46feet)	W3000*D900*H750(9.84*2.95*2.46feet)	Customized





BTCG-52 Model

Features:

- 1. 1.5cm thick desktop, large space and storage space
- 2. Health and environmental protection board E1 density board, fireproof, scratch proof, moisture-proof, durable and easy to clean
- 3. The side cabinet can be selected from left to right,
- 4. Piano baking paint, bright, eight coat paint process

Colors:white/colour customized

Size		
W1600*D800*H750 (5.24*2.62*2.46Feet)	W1800*D800*H750(5.9*2.62*2.46Feet)	W2000*D800*H750(6.56*2.62*2.46Feet)
W2200*D800*H750(7.21*2.62*2.46Feet)	W2400*D800*H750(7.87*2.65*2.46feet)	W2600*D900*H750(8.53*2.95*2.46feet)
W2800*D900*H750(9.18*2.95*2.46feet)	W3000*D900*H750(9.84*2.95*2.46feet)	Customized

BTCG-55 Model

Features:

- 1. 1.5cm thick desktop, sloping feet, large space and storage space
- 2. Health and environmental protection board E1 density board, fireproof, scratch proof, moisture-proof, durable and easy to clean
- 3. The side cabinet can be selected from left to right,
- 4. Piano baking paint, bright, eight coat paint process

Colors:white/colour customized

Size		
W1600*D800*H750 (5.24*2.62*2.46Feet)	W1800*D800*H750(5.9*2.62*2.46Feet)	W2000*D800*H750(6.56*2.62*2.46Feet)
W2200*D800*H750(7.21*2.62*2.46Feet)	W2400*D800*H750(7.87*2.65*2.46feet)	W2600*D900*H750(8.53*2.95*2.46feet)
W2800*D900*H750(9.18*2.95*2.46feet)	W3000*D900*H750(9.84*2.95*2.46feet)	Customized





BTCG-58 Model

Features:

- 1. 1.5cm thick desktop, large space and storage space
- 2. Health and environmental protection board E1 density board, fireproof, scratch proof, moisture-proof, durable and easy to clean
- 3. The side cabinet can be selected from left to right,
- 4. Piano baking paint, bright, eight coat paint process

Colors:white/colour customized

Size		
W1600*D800*H750 (5.24*2.62*2.46Feet)	W1800*D800*H750(5.9*2.62*2.46Feet)	W2000*D800*H750(6.56*2.62*2.46Feet)
W2200*D800*H750(7.21*2.62*2.46Feet)	W2400*D800*H750(7.87*2.65*2.46feet)	W2600*D900*H750(8.53*2.95*2.46feet)
W2800*D900*H750(9.18*2.95*2.46feet)	W3000*D900*H750(9.84*2.95*2.46feet)	Customized

BTCG-73 Model

Features:

- 1. 1.5cm thick desktop, sloping feet, large space and storage space
- 2. Health and environmental protection board E1 density board, fireproof, scratch proof, moisture-proof, durable and easy to clean
- 3. The side cabinet can be selected from left to right,
- 4. Piano baking paint, bright, eight coat paint process

Colors:white/colour customized

Size		
W1600*D800*H750 (5.24*2.62*2.46Feet)	W1800*D800*H750(5.9*2.62*2.46Feet)	W2000*D800*H750(6.56*2.62*2.46Feet)
W2200*D800*H750(7.21*2.62*2.46Feet)	W2400*D800*H750(7.87*2.65*2.46feet)	W2600*D900*H750(8.53*2.95*2.46feet)
W2800*D900*H750(9.18*2.95*2.46feet)	W3000*D900*H750(9.84*2.95*2.46feet)	Customized



BTCG-74 Model

Features:

- 1.5cm thick desktop, aerofoil large space and storage space
- Health and environmental protection board E1 density board, fireproof, scratch proof, moisture-proof, durable and easy to clean.
- The side cabinet can be selected from left to right,
- Piano baking paint, bright, eight coat paint process

Colors: white/colour customized

Size		
W1600*D700*H750 (5.24*2.62*2.46Feet)	W1800*D800*H750(5.9*2.62*2.46Feet)	W2000*D800*H750(6.56*2.62*2.46Feet)
W2200*D800*H750(7.21*2.62*2.46Feet)	W2400*D800*H750(7.87*2.65*2.46feet)	W2600*D900*H750(8.53*2.95*2.46feet)
W2800*D900*H750(9.18*2.95*2.46feet)	W3000*D900*H750(9.84*2.95*2.46feet)	Customized

BTCG-75 Model

Features:

- 1.5cm thick desktop, sloping feet, large space and storage space
- Health and environmental protection board E1 density board, fireproof, scratch proof, moisture-proof, durable and easy to clean
- The side cabinet can be selected from left to right,
- Piano baking paint, bright, eight coat paint process

Colors: white/colour customized

Size		
W1600*D700*H750 (5.24*2.62*2.46Feet)	W1800*D800*H750(5.9*2.62*2.46Feet)	W2000*D800*H750(6.56*2.62*2.46Feet)
W2200*D800*H750(7.21*2.62*2.46Feet)	W2400*D800*H750(7.87*2.65*2.46feet)	W2600*D900*H750(8.53*2.95*2.46feet)
W2800*D900*H750(9.18*2.95*2.46feet)	W3000*D900*H750(9.84*2.95*2.46feet)	Customized

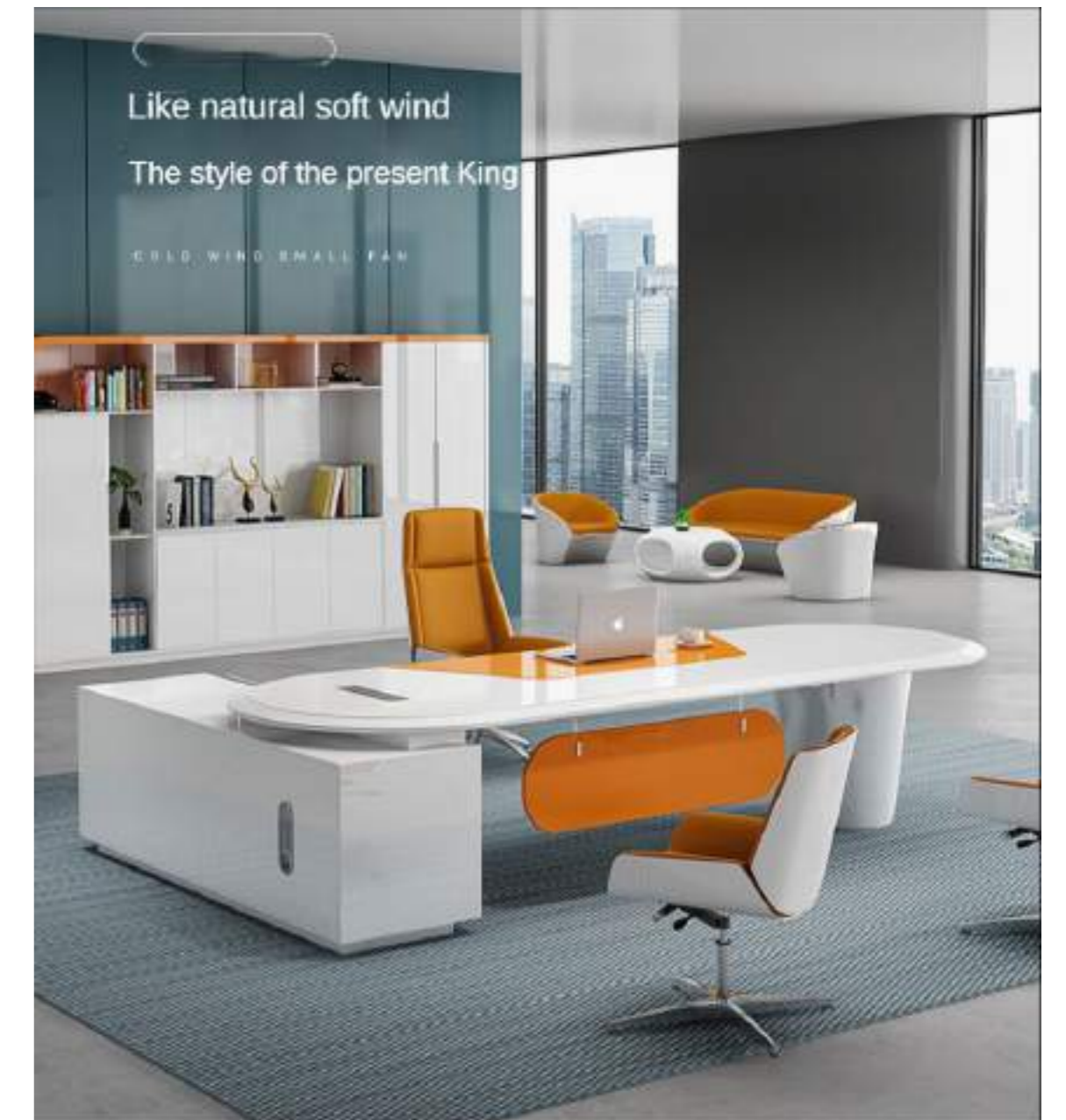



BTCG-76 Model

Features:

- 1. 1.5cm thick desktop, aerofoil large space and storage space
- 2. Health and environmental protection board E1 density board, fireproof, scratch proof, moisture-proof, durable and easy to clean
- 3. The side cabinet can be selected from left to right,
- 4. Piano baking paint, bright, eight coat paint process

Colors:white/colour customized

Size		
W1600*D800*H750 (5.24*2.62*2.46Feet)	W1800*D800*H750(5.9*2.62*2.46Feet)	W2000*D800*H750(6.56*2.62*2.46Feet)
W2200*D800*H750(7.21*2.62*2.46Feet)	W2400*D800*H750(7.87*2.65*2.46feet)	W2600*D900*H750(8.53*2.95*2.46feet)
W2800*D900*H750(9.18*2.95*2.46feet)	W3000*D900*H750(9.84*2.95*2.46feet)	Customized

BTCG-92 Model

Features:

- 1. 1.5cm thick desktop, sloping feet, large space and storage space
- 2. Health and environmental protection board E1 density board, fireproof, scratch proof, moisture-proof, durable and easy to clean
- 3. The side cabinet can be selected from left to right,
- 4. Piano baking paint, bright, eight coat paint process

Colors:white/colour customized

Size		
W1600*D800*H750 (5.24*2.62*2.46Feet)	W1800*D800*H750(5.9*2.62*2.46Feet)	W2000*D800*H750(6.56*2.62*2.46Feet)
W2200*D800*H750(7.21*2.62*2.46Feet)	W2400*D800*H750(7.87*2.65*2.46feet)	W2600*D900*H750(8.53*2.95*2.46feet)
W2800*D900*H750(9.18*2.95*2.46feet)	W3000*D900*H750(9.84*2.95*2.46feet)	Customized





BTCG-93 Model

Features:

- 1. 1.5cm thick desktop, aerofoil large space and storage space
- 2. Health and environmental protection board E1 density board, fireproof, scratch proof, moisture-proof, durable and easy to clean
- 3. The side cabinet can be selected from left to right,
- 4. Piano baking paint, bright, eight coat paint process

Colors:white/colour customized

Size		
W1600*D800*H750 (5.24*2.62*2.46Feet)	W1800*D800*H750(5.9*2.62*2.46Feet)	W2000*D800*H750(6.56*2.62*2.46Feet)
W2200*D800*H750(7.21*2.62*2.46Feet)	W2400*D800*H750(7.87*2.65*2.46feet)	W2600*D900*H750(8.53*2.95*2.46feet)
W2800*D900*H750(9.18*2.95*2.46feet)	W3000*D900*H750(9.84*2.95*2.46feet)	Customized

BTCG-94 Model

- Features:**
- 1. 1.5cm thick desktop, sloping feet, large space and storage space
 - 2. Health and environmental protection board E1 density board, fireproof, scratch proof, moisture-proof, durable and easy to clean
 - 3. The side cabinet can be selected from left to right,
 - 4. Piano baking paint, bright, eight coat paint process

Colors:white/colour customized

Size		
W1600*D800*H750 (5.24*2.62*2.46Feet)	W1800*D800*H750(5.9*2.62*2.46Feet)	W2000*D800*H750(6.56*2.62*2.46Feet)
W2200*D800*H750(7.21*2.62*2.46Feet)	W2400*D800*H750(7.87*2.65*2.46feet)	W2600*D900*H750(8.53*2.95*2.46feet)
W2800*D900*H750(9.18*2.95*2.46feet)	W3000*D900*H750(9.84*2.95*2.46feet)	Customized



Classical style CEO desk

BTCG-20 Model



Features:

- 1.80mm thick desktop, large space and storage space
- Health and environmental protection board, high-density board, fireproof, scratch proof, moisture-proof, durable and easy to clean
- The side cabinet can be selected from left to right,
- The surface is pasted with solid wood veneer, bright and eight coats of paint+PU leather on desktop

Colors:Reddish brown/colour customized

Size		
W2600*D900*H760(8.53*2.95*2.49feet)	W2800*D1150*H760(9.18*3.77*2.49feet)	W3200*D1200*H760 (10.49*3.93*2.49feet)
Customized		

BTCG-21 Model

Features:

- 1.80mm thick desktop, large space and storage space
- Health and environmental protection board, high-density board, fireproof, scratch proof, moisture-proof, durable and easy to clean
- The side cabinet can be selected from left to right,
- The surface is pasted with solid wood veneer, bright and eight coats of paint+PU leather on desktop

Colors:Reddish brown/colour customized

Size		
W1600*D800*H760(5.24*2.62*2.49feet)	W1800*D900*H760(5.9*2.95*2.49feet)	W2000*D1000*H760(6.56*3.28*2.49feet)
W2200*D1050*H760(7.21*3.44*2.49feet)	W2400*D1080*H760(7.87*3.54*2.49feet)	W2800*D1150*H760(9.18*3.77*2.49feet)
W3200*D1200*H760 (10.49*3.93*2.49feet)	Customized	





BTCG-22 Model

Features:

- 1. 1.80mm thick desktop, large space and storage space
- 2. Health and environmental protection board, high-density board, fireproof, scratch proof, moisture-proof, durable and easy to clean
- 3. The side cabinet can be selected from left to right,
- 4. The surface is pasted with solid wood veneer, bright and eight coats of paint+PU leather on desktop

Colors:Reddish brown/colour customized

Size		
W1600*D800*H760(5.24*2.62*2.49feet)	W1800*D900*H760(5.9*2.95*2.49feet)	W2000*D1000*H760(6.56*3.28*2.49feet)
W2200*D1050*H760(7.21*3.44*2.49feet)	W2400*D1080*H760(7.87*3.54*2.49feet)	W2800*D1150*H760(9.18*3.77*2.49feet)
W3200*D1200*H760 (10.49*3.93*2.49feet)	Customized	

BTCG-23 Model

Features:

- 1. 1.80mm thick desktop, large space and storage space
- 2. Health and environmental protection board, high-density board, fireproof, scratch proof, moisture-proof, durable and easy to clean
- 3. The side cabinet can be selected from left to right,
- 4. The surface is pasted with solid wood veneer, bright and eight coats of paint+PU leather on desktop

Colors:Reddish brown/colour customized

Size		
W1600*D800*H760(5.24*2.62*2.49feet)	W1800*D900*H760(5.9*2.95*2.49feet)	W2000*D1000*H760(6.56*3.28*2.49feet)
W2200*D1050*H760(7.21*3.44*2.49feet)	W2400*D1080*H760(7.87*3.54*2.49feet)	W2800*D1150*H760(9.18*3.77*2.49feet)
W3200*D1200*H760 (10.49*3.93*2.49feet)	Customized	



BTCG-24 Model



Features:

- 1.80mm thick desktop, large space and storage space
- Health and environmental protection board, high-density board, fireproof, scratch proof, moisture-proof, durable and easy to clean
- The side cabinet can be selected from left to right,
- The surface is pasted with solid wood veneer, bright and eight coats of paint+PU leather on desktop

Colors:Reddish brown/colour customized

Size		
W1600*D800*H760(5.24*2.62*2.49feet)	W1800*D900*H760(5.9*2.95*2.49feet)	W2000*D1000*H760(6.56*3.28*2.49feet)
W2200*D1050*H760(7.21*3.44*2.49feet)	W2400*D1080*H760(7.87*3.54*2.49feet)	W2800*D1150*H760(9.18*3.77*2.49feet)
W3200*D1200*H760 (10.49*3.93*2.49feet)	Customized	

BTCG-25 Model

Features:

- 1.80mm thick desktop, large space and storage space
- Health and environmental protection board, high-density board, fireproof, scratch proof, moisture-proof, durable and easy to clean
- The side cabinet can be selected from left to right,
- The surface is pasted with solid wood veneer, bright and eight coats of paint+PU leather on desktop

Colors:Reddish brown/colour customized

Size		
W1600*D800*H760(5.24*2.62*2.49feet)	W1800*D900*H760(5.9*2.95*2.49feet)	W2000*D1000*H760(6.56*3.28*2.49feet)
W2200*D1050*H760(7.21*3.44*2.49feet)	W2400*D1080*H760(7.87*3.54*2.49feet)	W2800*D1150*H760(9.18*3.77*2.49feet)
W3200*D1200*H760 (10.49*3.93*2.49feet)	Customized	





BTCG-26 Model

Features:

- 1. 1.80mm thick desktop, large space and storage space
- 2. Health and environmental protection board, high-density board, fireproof, scratch proof, moisture-proof, durable and easy to clean
- 3. The side cabinet can be selected from left to right,
- 4. The surface is pasted with solid wood veneer, bright and eight coats of paint+PU leather on desktop

Colors:Reddish brown/colour customized

Size		
W1600*D800*H760(5.24*2.62*2.49feet)	W1800*D900*H760(5.9*2.95*2.49feet)	W2000*D1000*H760(6.56*3.28*2.49feet)
W2200*D1050*H760(7.21*3.44*2.49feet)	W2400*D1080*H760(7.87*3.54*2.49feet)	W2800*D1150*H760(9.18*3.77*2.49feet)
W3200*D1200*H760(10.49*3.93*2.49feet)	Customized	

BTCG-27 Model

Features:

- 1. 1.80mm thick desktop, large space and storage space
- 2. Health and environmental protection board, high-density board, fireproof, scratch proof, moisture-proof, durable and easy to clean
- 3. The side cabinet can be selected from left to right,
- 4. The surface is pasted with solid wood veneer, bright and eight coats of paint+PU leather on desktop

Colors:Reddish brown/colour customized

Size		
W1600*D800*H760(5.24*2.62*2.49feet)	W1800*D900*H760(5.9*2.95*2.49feet)	W2000*D1000*H760(6.56*3.28*2.49feet)
W2200*D1050*H760(7.21*3.44*2.49feet)	W2400*D1080*H760(7.87*3.54*2.49feet)	W2800*D1150*H760(9.18*3.77*2.49feet)
W3200*D1200*H760 (10.49*3.93*2.49feet)	Customized	





BTCG-28 Model

Features:

- 1. 1.80mm thick desktop, large space and storage space
- 2. Health and environmental protection board, high-density board, fireproof, scratch proof, moisture-proof, durable and easy to clean
- 3. The side cabinet can be selected from left to right,
- 4. The surface is pasted with solid wood veneer, bright and eight coats of paint+PU leather on desktop

Colors:Reddish brown/colour customized

Size		
W1600*D800*H760(5.24*2.62*2.49feet)	W1800*D900*H760(5.9*2.95*2.49feet)	W2000*D1000*H760(6.56*3.28*2.49feet)
W2200*D1050*H760(7.21*3.44*2.49feet)	W2400*D1080*H760(7.87*3.54*2.49feet)	W2800*D1150*H760(9.18*3.77*2.49feet)
W3200*D1200*H760 (10.49*3.93*2.49feet)	Customized	

BTCG-29 Model

Features:

- 1. 1.80mm thick desktop, large space and storage space
- 2. Health and environmental protection board, high-density board, fireproof, scratch proof, moisture-proof, durable and easy to clean
- 3. The side cabinet can be selected from left to right,
- 4. The surface is pasted with solid wood veneer, bright and eight coats of paint+PU leather on desktop

Colors:Reddish brown/colour customized

Size		
W1600*D800*H760(5.24*2.62*2.49feet)	W1800*D900*H760(5.9*2.95*2.49feet)	W2000*D1000*H760(6.56*3.28*2.49feet)
W2200*D1050*H760(7.21*3.44*2.49feet)	W2400*D1080*H760(7.87*3.54*2.49feet)	W2800*D1150*H760(9.18*3.77*2.49feet)
W3200*D1200*H760(10.49*3.93*2.49feet)	Customized	



BTCG-30 Model

Features:

- 1.80mm thick desktop, large space and storage space
- Health and environmental protection board, high-density board, fireproof, scratch proof, moisture-proof, durable and easy to clean
- The side cabinet can be selected from left to right,
- The surface is pasted with solid wood veneer, bright and eight coats of paint+PU leather on desktop

Colors:Reddish brown/colour customized

Size		
W1600*D800*H760(5.24*2.62*2.49feet)	W1800*D900*H760(5.9*2.95*2.49feet)	W2000*D1000*H760(6.56*3.28*2.49feet)
W2200*D1050*H760(7.21*3.44*2.49feet)	W2400*D1080*H760(7.87*3.54*2.49feet)	W2800*D1150*H760(9.18*3.77*2.49feet)
W3200*D1200*H760(10.49*3.93*2.49feet)	Customized	



BTCG-31 Model

Features:

- 1.80mm thick desktop, large space and storage space
- Health and environmental protection board, high-density board, fireproof, scratch proof, moisture-proof, durable and easy to clean
- The side cabinet can be selected from left to right,
- The surface is pasted with solid wood veneer, bright and eight coats of paint+PU leather on desktop

Colors:Reddish brown/colour customized

Size		
W1600*D800*H760(5.24*2.62*2.49feet)	W1800*D900*H760(5.9*2.95*2.49feet)	W2000*D1000*H760(6.56*3.28*2.49feet)
W2200*D1050*H760(7.21*3.44*2.49feet)	W2400*D1080*H760(7.87*3.54*2.49feet)	W2800*D1150*H760(9.18*3.77*2.49feet)
W3200*D1200*H760 (10.49*3.93*2.49feet)	Customized	





BTCG-32 Model

Features:

- 1. 1.80mm thick desktop, large space and storage space
- 2. Health and environmental protection board, high-density board, fireproof, scratch proof, moisture-proof, durable and easy to clean
- 3. The side cabinet can be selected from left to right,
- 4. The surface is pasted with solid wood veneer, bright and eight coats of paint+PU leather on desktop

Colors:Reddish brown/colour customized

Size		
W1600*D800*H760(5.24*2.62*2.49feet)	W1800*D900*H760(5.9*2.95*2.49feet)	W2000*D1000*H760(6.56*3.28*2.49feet)
W2200*D1050*H760(7.21*3.44*2.49feet)	W2400*D1080*H760(7.87*3.54*2.49feet)	W2800*D1150*H760(9.18*3.77*2.49feet)
W3200*D1200*H760 (10.49*3.93*2.49feet)	Customized	

BTCG-33 Model

Features:

- 1. 1.80mm thick desktop, large space and storage space
- 2. Health and environmental protection board, high-density board, fireproof, scratch proof, moisture-proof, durable and easy to clean
- 3. The side cabinet can be selected from left to right,
- 4. The surface is pasted with solid wood veneer, bright and eight coats of paint+PU leather on desktop

Colors:Reddish brown/colour customized

Size		
W1600*D800*H760(5.24*2.62*2.49feet)	W1800*D900*H760(5.9*2.95*2.49feet)	W2000*D1000*H760(6.56*3.28*2.49feet)
W2200*D1050*H760(7.21*3.44*2.49feet)	W2400*D1080*H760(7.87*3.54*2.49feet)	W2800*D1150*H760(9.18*3.77*2.49feet)
W3200*D1200*H760(10.49*3.93*2.49feet)	Customized	



BTCG-32 Model



Features:

- 1.80mm thick desktop, large space and storage space
- Health and environmental protection board, high-density board, fireproof, scratch proof, moisture-proof, durable and easy to clean
- The side cabinet can be selected from left to right,
- The surface is pasted with solid wood veneer, bright and eight coats of paint+PU leather on desktop

Colors:Reddish brown/colour customized

Size		
W1600*D800*H760(5.24*2.62*2.49feet)	W1800*D900*H760(5.9*2.95*2.49feet)	W2000*D1000*H760(6.56*3.28*2.49feet)
W2200*D1050*H760(7.21*3.44*2.49feet)	W2400*D1080*H760(7.87*3.54*2.49feet)	W2800*D1150*H760(9.18*3.77*2.49feet)
W3200*D1200*H760(10.49*3.93*2.49feet)	Customized	



Office Chair

Sit well to do well. An office chair that can read your needs. A good chair is healthy, fits the body curve, and has a healthy career,

YZCG-1 Model



Steel five-star foot

Features:

1. Streamlined fixed handrail, lifting button, stainless steel five-star foot, thickened high elastic sponge.
2. Ergonomic backrest design, tear resistant mesh. Return waist support, strong support and wear resistance.
3. SGS certified pneumatic rod. Silent pulley, no damage to the floor, no noise,.
4. Size: 600 * 600 * 950 (1.96 * 1.96 * 3.11 feet)

Colors:black / custom color



Fixed support

YZCG-2 Model

Features:

1. S-shaped backrest, drag your back.
2. Circulating mesh, chair back and tear proof mesh. Breathable, good wear resistance.
3. Original sponge cushion, high rebound. Steel support, strong supporting force,
4. Size: 700 * 520 * 760 (2.29 * 1.7 * 2.49 feet)

Colors:black / custom color



YZCG-4 Model

Features:

1. S-shaped ergonomic backrest, drag your back.
2. Thickened high rebound sponge, 3D handrail, stable drag bearing. Solid and durable thickened xipi. 150 ° tilt back adjustment
3. Stainless steel bearing five-star foot, Pu silent pulley, steel explosion-proof tray and explosion-proof air rod
4. Size: W600 * D600 * h1260 (2.29 * 1.7 * 2.49 feet)

Colors:black / custom color



YZCG-3 Model



Steel five-star foot



Fixed support



Five star foot + pillow

Features:

1. High density sponge, compression and fall resistance, elastic breathable mesh, wear-resistant, cool and breathable.
2. Ergonomic backrest design. Return lumbar support, strong support and good wear resistance.
3. The tilt back angle can be adjusted to 120 ° , smooth handrail and SGS certified air rod
4. Size: 650 * 580 * 950 (2.13 * 1.9 * 3.11 feet)

Colors:black / custom color

YZCG-6 Model

Features:

1. High density sponge, compression and fall resistance, elastic breathable mesh, wear-resistant, cool and breathable.
2. Ergonomic backrest design. Return lumbar support, strong support and good wear resistance.
3. The tilt back angle can be adjusted to 120 ° , smooth handrail and SGS certified air rod
4. Size: W650 * D580 * H950 (2.13 * 1.9 * 3.11 feet)

Colors:black / custom color



Steel five-star foot



Fixed steel frame

YZCG-7 Model

Features:

1. High quality PU leather is flexible, tear resistant, skin friendly, breathable and elastic
2. High rebound sponge filling, exquisite routing, 120 ° tilt back. Ergonomic design,
3. Thickened explosion-proof tray, SGS certified three-level pneumatic rod, aluminum alloy five-star foot
4. High back size: W600 * D600 * h1340 (1.96 * 1.96 * 4.39 feet)
Low back size: W600 * D600 * H1240 (1.96 * 1.96 * 4.06 feet)

Colors:black / custom color



High back



Low back



YZCG-9 Model

Features:

- 1. High quality PU leather is flexible, tear resistant, skin friendly, breathable and elastic
- 2. High rebound sponge filling, exquisite routing, 120 ° tilt back. Ergonomic design,
- 3. Thickened explosion-proof tray, SGS certified three-level pneumatic rod, aluminum alloy five-star foot

Colors:black / custom color

YZCG-10 Model

Features:

- 1. High quality leather art + native sponge, compression and falling resistant, load-bearing steel pipe. Oversized backrest, multifunctional pull rod
- 2. Ergonomic backrest design. S-shaped curve waist protection. Filled with high rebound sponge, it has strong support and good wear resistance.
- 3. The handrail is smooth and equipped with SGS certified air rod
- 4. High back Size: W560 * D550 * H1070 (1.83*1.8* 3.51 feet)
Middle back Size:W560 * D550 * H850 (1.83*1.8* 2.78 feet)



High back



Middle back

Colors:black / custom color

YZCG-5 Model

Features:

- 1. High quality leather art + native sponge, compression and falling resistant, load-bearing steel pipe. Oversized backrest, multifunctional pull rod
- 2. Ergonomic backrest design. S-shaped curve waist protection. Filled with high rebound sponge, it has strong support and good wear resistance.
- 3. The handrail is smooth and equipped with SGS certified air rod
- 4. High back Size: W560 * D550 * H1070 (1.83*1.8* 3.51 feet)
Middle back Size:W560 * D550 * H850 (1.83*1.8* 2.78 feet)



High back



Low back

Colors:black / custom color

YZCG-11 Model



High back
painted backrest
Pulley foot



High back walnut skin
fixed steel frame

Features:

1. Engineering design, chair back design, lifting, cervical spine protection and shoulder vertebrae protection. Filled with high-density rebound sponge. Selected super fiber technology leather.
2. 120 ° tilt back adjustment, Pu silent pulley, aluminum alloy bearing five-star foot. Two kinds of chair feet are available.
3. The multi-layer curved board is pasted with wood veneer and painted backrest, and the multi-functional explosion-proof site
4. High back size: 660 * 660 * 1170mm (2.16 * 2.16 * 3.83 feet)
Middle back size: 660 * 660 * 900 (2.16 * 2.16 * 2.95 feet)

Colors:black / custom color



Middle back water
curved skin +
fixed steel frame



Middle back paint
baking + pulley
steel frame

YZCG-8 Model

Features:

1. Streamlined fixed handrail, lifting button, stainless steel five-star foot, thickened high elastic sponge.
2. Ergonomic backrest design, tear resistant mesh. Return waist support, strong support and wear resistance.
3. SGS certified pneumatic rod. Silent pulley, no damage to the floor, no noise,.

Colors:black / custom color



YZCG-13 Model

Features:

1. S-shaped backrest, drag your back.
2. Circulating mesh, chair back and tear proof mesh. Breathable, good wear resistance.
3. Original sponge cushion, high rebound. Steel support, strong supporting force,
4. Size: 450 * 460 * 900 (1.47*1.5*2.95 feet)

Colors:black / custom color



YZCG-14 Model



High back pulley



High back fixed steel frame

Features:

1. High quality mesh + native sponge, compression and falling resistant, load-bearing steel pipe. Oversized backrest, multifunctional pull rod
2. Ergonomic backrest design. S-shaped curve waist protection. Filled with high rebound sponge, it has strong support and good wear resistance.
3. The handrail is smooth and equipped with SGS certified air rod
4. High back Size: W560 * D550 * H1070 (1.83*1.8* 3.51 feet)
Middle back Size:W560 * D550 * H850 (1.83*1.8* 2.78 feet)

Colors:black / custom color



High back pulley



High back fixed steel frame

YZCG-17 Model

Features:

1. Breathable mesh, wear-resistant, dirt resistant, flexible and elastic.
2. The S-shaped curved backrest design conforms to ergonomics and is close to the back support ridge
3. It is filled with high elastic sponge and is not easy to deform.
4. Size:W480*D560*H950(1.57*1.83*3.11 feet)

Colors:black / custom color



YZCG-18 Model

Features:

1. Arc design, multi-functional adjustment. The chair legs are strong.**Foldable**
2. Fit the back, three-dimensional support, breathable and resilient cushion
3. Strong bearing capacity, engineering handrail
4. Size:W620*D595*H865(2.03*1.95*2.83 feet)

Colors:black / custom color



YZCG-21 Model



High back pulley



High back fixed foot

Features:

1. Fit the spine curve and double-layer backrest. Aluminum alloy five-star foot, wear-resistant and corrosion-resistant
2. Technology imitation wood grain leather, lifting adjustment, 120 ° free and carefree. Integrated head restraint
3. The original high-density sponge has good elasticity and is not tired.
4. High back size: w660 * D660 * h1270 (2.16 * 2.16 * 4.16 feet)
Middle back size: w660 * D660 * h1040 (2.16 * 2.16 * 3.41 feet)

Colors:black / custom color



Middle back pulley



Middle back fixed foot

YZCG-19 Model

Features:

1. Full lines, ergonomic chair, with massage function.
2. The chair becomes a bed with a built-in spring bag. S-shaped radian natural fit, double-layer thickening.
3. It is filled with high elastic sponge, with good elasticity of seat cushion and backrest and telescopic foot pad.
4. Size: W640 * D600 * h1120 (2.09 * 1.96 * 3.67 feet)

Colors:black / custom color



YZCG-30 Model

Features:

1. S-shaped backrest, drag your back.Lifting and adjusting headrest
2. Circulating mesh, chair back and tear proof mesh. Breathable, good wear resistance.
3. Original sponge cushion, high rebound. Steel support, strong supporting force,
4. Size: W580*D580*H1130 (1.9*1.9*3.7 feet)

Colors:black / custom color





Pulley

YZCG-22 Model

Features:

- 1. S-shaped backrest, drag your back.
- 2. Circulating mesh, chair back and tear proof mesh. Breathable, good wear resistance.
- 3. Original sponge cushion, high rebound. Steel support, strong supporting force,
- 4. Size: W580*D580*H1130 (1.9*1.9*3.7 feet)

Colors:black / custom color



Fixed steel frame

YZCG-23 Model

Features:

- 1. High quality PU leather is flexible, tear resistant, skin friendly, breathable and elastic
- 2. High rebound sponge filling, exquisite routing, 120 ° tilt back. Ergonomic design,
- 3. Thickened explosion-proof tray, SGS certified three-level pneumatic rod, aluminum alloy five-star foot

Colors:black / custom color



YZCG-24 Model

Features:

- 1. S-shaped backrest, drag your back.Lifting and adjusting headrest
- 2. Circulating mesh, chair back and tear proof mesh. Breathable, good wear resistance.
- 3. Original sponge cushion, high rebound. Steel support, strong supporting force,

Colors:black / custom color



YZCG-5 Model

Features:

1. 3D thickened high rebound cushion, PU leather.
2. Injection molded PP handrail, radian square tube, strong bearing capacity
3. Size:W600*D600*H1000(1.96*1.96*3.28 feet)

Colors:black / custom color



YZCG-32 Model

Features:

- Fabric: mesh
- Backrest armrest: Nylon
- Three stage air rod
- Base plate: new plate
- Pu roller 310 nylon foot
- Primary sponge
- Size:W600*D600*H1080(1.96*1.96*3.54 feet)

Colors:black / custom color



YZCG-26 Model

Features:

1. 160 ° adjustable, pull-out foot pad, double-layer thickened headrest.
2. Curved handrail, easy to take care of. The seat cushion is breathable. Ergonomic design.
3. High resilience sponge, environmental protection, health, comfort and durability.

Colors:black / custom color



YZCG-28 Model

Features:

1. 160 ° adjustable, pull-out foot pad, double-layer thickened headrest.
2. Curved handrail, easy to take care of. The seat cushion is breathable. Ergonomic design.
3. High resilience sponge, environmental protection, health, comfort and durability.

Colors:black / custom color

YZCG-33 Model

Features:

- Fabric: single and double mesh
- Backrest armrest: Nylon
- Three stage air rod
- Base plate: new plate
- Pu roller 300 nylon foot
- Primary sponge
- 4. Size: W640*D640*H1100(2.09*2.09*3.6 feet)

Colors:black / custom color



YZCG-34 Model

Features:

- Fabric: mesh
- Backrest armrest: Nylon
- Three stage air rod
- Base plate: new plate
- Pu roller 310 nylon foot
- 17 xiaoyaotuo native sponge
- 4. Size: W640*D640*H1250(2.09*2.09*4.1 feet)

Colors:black / custom color



YZCG-29 Model

Features:

1. S-shaped backrest, drag your back.Lifting and adjusting headrest
2. Circulating mesh, chair back and tear proof mesh. Breathable, good wear resistance.
3. Original sponge cushion, high rebound. Steel support, strong supporting force,
4. Size: W580*D580*H1130 (1.9*1.9*3.7 feet)

Colors:black / custom color



YZCG-31 Model

Features:

1. S-shaped backrest, drag your back.
2. Circulating mesh, chair back and tear proof mesh. Breathable, good wear resistance.
3. Original sponge cushion, high rebound. Steel support, strong supporting force,
4. Size: W580*D580*H1130 (1.9*1.9*3.7 feet)

Colors:black / custom color



YZCG-35 Model

Features:

Fabric: PVC sponge: 60 density recycled sponge + 24 density new cotton handrail: PP plus glass fiber + PVC foot rest: iron frame + PVC + recycled cotton + wood plate chassis: lying support air rod: 100mm air rod five claws Foot: 320mm steel foot or nylon foot wheel: 50mm PU wheel4. Size: W650*D650*H1260(2.13*2.13*4.13 feet)

Colors:black / custom color



YZCG-36Model

Features:

1. High elastic mesh, breathable and hygroscopic. The seat cushion is made of high elastic sponge with strong load-bearing.
2. Ergonomic chair, nylon armrest and lumbar cushion for soothing spine
3. Size: W600 * D600 * 1000 (1.96 * 1.96 * 3.28 feet))

Colors:black / custom color



YZCG-20 Model

Features:

1. Fit the spine curve and double-layer backrest. Aluminum alloy five-star foot, wear-resistant and corrosion-resistant
2. Technology imitation wood grain leather, lifting adjustment, 120 ° free and carefree. Integrated head restraint
3. The original high-density sponge has good elasticity and is not tired.
4. High back size: w660 * D660 * h1270 (2.16 * 2.16 * 4.16 feet)
Middle back size: w660 * D660 * h1040 (2.16 * 2.16 * 3.41 feet)

Colors:black / custom color



High back



Middle back

YZCG-37 Model

Features:

1. High quality PU leather is flexible, tear resistant, skin friendly, breathable and elastic
2. High rebound sponge filling, exquisite routing, Can lie. Ergonomic design,
3. Thickened explosion-proof tra SGS certified three-level pneumatic rod, aluminum alloy five-star foot

Colors:black / custom color



YZCG-38 Model

Features:

1. High quality PU leather is flexible, tear resistant, skin friendly, breathable and elastic
2. High rebound sponge filling, exquisite routing, Can lie. Ergonomic design,
3. Thickened explosion-proof tray, SGS certified three-level pneumatic rod, aluminum alloy five-star foot
Wooden handrail

Colors:black / custom color



YZCG-39 Model

Features:

1. High quality PU leather is flexible, tear resistant, skin friendly, breathable and elastic
2. High rebound sponge filling, exquisite routing, Can lie. Ergonomic design,
3. Thickened explosion-proof tray, SGS certified three-level pneumatic rod, aluminum alloy five-star foot
Wooden handrail

Colors:black / custom color



YZCG-40 Model

Features:

1. High quality PU leather is flexible, tear resistant, skin friendly, breathable and elastic
2. High rebound sponge filling, exquisite routing, Can lie. Ergonomic design,
3. Thickened explosion-proof tray, SGS certified three-level pneumatic rod, aluminum alloy five-star foot
Wooden handrail

Colors:black / custom color



YZCG-41 Model

Features:

1. High quality PU leather is flexible, tear resistant, skin friendly, breathable and elastic
2. High rebound sponge filling, exquisite routing, Can lie. Ergonomic design,
3. Thickened explosion-proof tray, SGS certified three-level pneumatic rod, aluminum alloy five-star foot

Colors:black / custom color



YZCG-42 Model

Features:

- Fabric: single and double mesh
- Backrest armrest: Nylon
- Three stage air rod
- Base plate: new plate
- Pu roller 300 nylon foot
- Primary sponge
- 4. Size: W640*D640*H1100(2.09*2.09*3.6 feet)

Colors:black / custom color



YZCG-43 Model

Features:

- Fabric: mesh
- Backrest armrest: Nylon
- Three stage air rod
- Base plate: new plate
- Pu roller 310 nylon foot
- 17 xiaoyaotuo native sponge
- 4. Size: W640*D640*H1250(2.09*2.09*4.1 feet)

Colors:black / custom color



YZCG-44 Model

Features:

1. S-shaped backrest, drag your back.Lifting and adjusting headrest
2. Circulating mesh, chair back and tear proof mesh. Breathable, good wear resistance.
3. Original sponge cushion, high rebound. Steel support, strong supporting force,
4. Size: W580*D580*H1130 (1.9*1.9*3.7 feet)

Colors:black / custom color



YZCG-45 Model

Features:

1. S-shaped backrest, drag your back.
2. Circulating mesh, chair back and tear proof mesh. Breathable, good wear resistance.
3. Original sponge cushion, high rebound. Steel support, strong supporting force,
4. Size: W580*D580*H1130 (1.9*1.9*3.7 feet)

Colors:black / custom color



YZCG-47 Model

Features:

Fabric: single and double mesh
Backrest armrest: Nylon
Three stage air rod
Base plate: new plate
Pu roller 300 nylon foot
Primary sponge

Colors:black / custom color



YZCG-48 Model

Features:

Fabric: mesh
Backrest armrest: Nylon
Three stage air rod
Base plate: new plate
Pu roller 310 nylon foot
17 xiaoyaotuo native sponge4. Size:

Colors:black / custom color

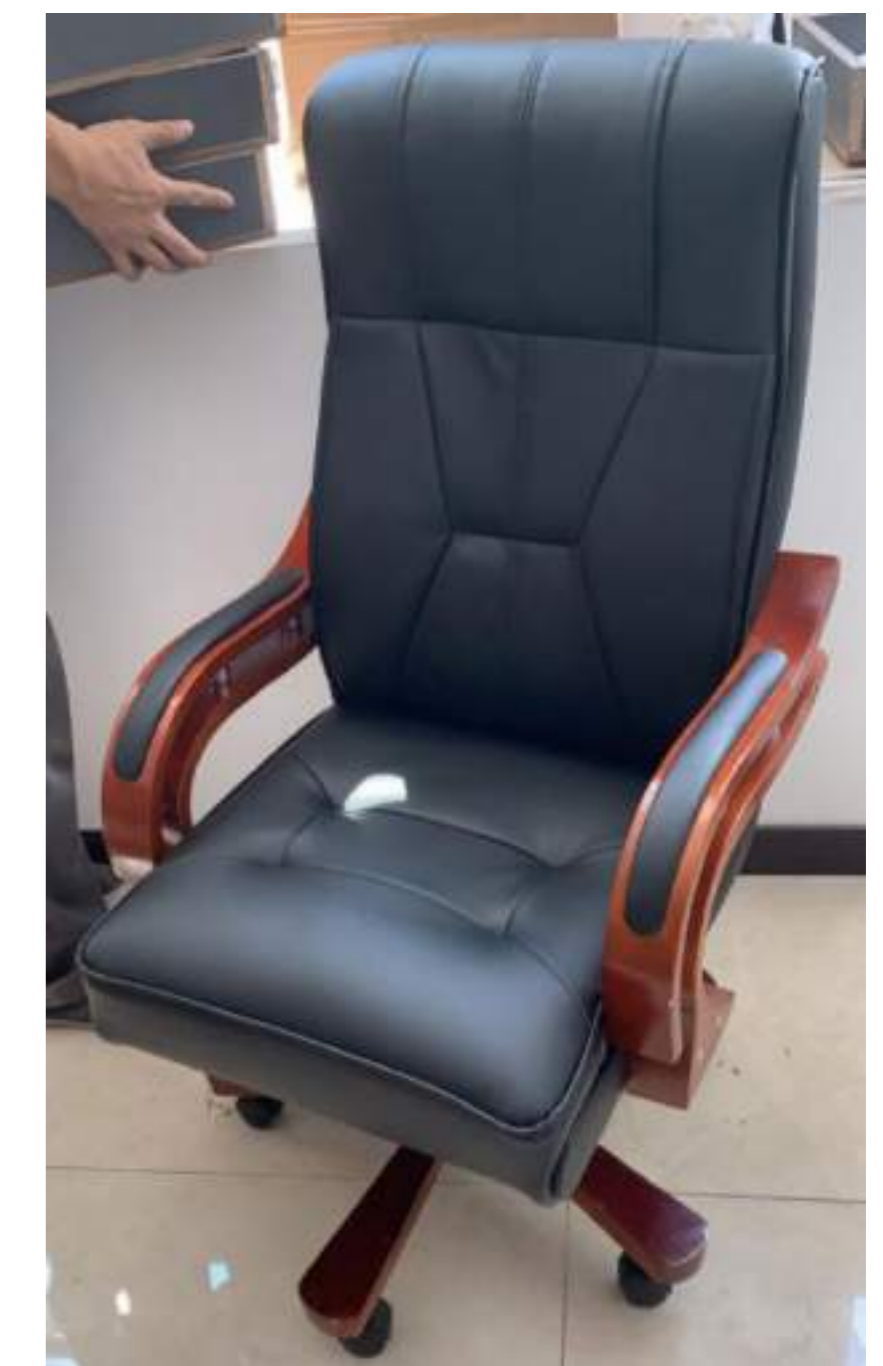

YZCG-49 Model

Features:

1. S-shaped backrest, drag your back.Lifting and adjusting headrest
2. Circulating mesh, chair back and tear proof mesh. Breathable, good wear resistance.
3. Original sponge cushion, high rebound. Steel support, strong supporting force,

Colors:black / custom color





An ergonomic office chair is essential for maintaining good posture, avoiding physical discomfort and boosting productivity.

Ergonomic office chairs are designed to place your comfort and good posture above all else. Expect to be fully supported with backrests, soft seat cushions, a variety of height adjustments and lumbar support. An office chair as ergonomic and cushioned as those available at Vico ensure your comfort throughout long work days or study sessions.

OFFICE CHAIR COLLECTION





VC8012PA-H

- ergonomic design
- adjustable lumbar support
- adjustable head support
- adjustable armrest



VC8012PA

- ergonomic design
- adjustable lumbar support
- adjustable armrest



VC8012P-H

- ergonomic design
- adjustable lumbar support
- adjustable head support







VC8008P-H

- ergonomic design
- adjustable lumbar support
- adjustable head support



VC8008P

- ergonomic design
- adjustable lumbar support



VC8008PA-H

- ergonomic design
- adjustable lumbar support
- adjustable head support
- adjustable armrest







VC8002P

- foldable back
- adjustable armrest
- tilt tension with lock mechanism



VC8002M

- foldable back
- adjustable armrest
- tilt tension with lock mechanism



VC8002A

- foldable back
- adjustable armrest
- bent steel base







VC8501M

- reclinable back
- head support
- tilt tension with lock mechanism



VC8501M-F

- reclinable back
- head support
- extend-retract foot support
- tilt tension with lock mechanism



VC8501A

- reclinable back
- head support
- bent steel base







VC8901P

- adjustable lumbar support
- adjustable armrest
- tilt tension with lock mechanism



VC8901M

- adjustable lumbar support
- adjustable armrest
- tilt tension with lock mechanism



VC8901P-H

- adjustable lumbar support
- adjustable head support
- adjustable armrest
- tilt tension with lock mechanism





VC8016P

- ergonomic design
- lumbar support
- tilt tension with lock mechanism



VC8016P-H

- ergonomic design
- lumbar support
- adjustable head support
- tilt tension with lock mechanism



VC8016A

- ergonomic design
- lumbar support
- bent steel base





VC8017P

- ergonomic design
- lumbar support
- tilt tension with lock mechanism



VC8017M

- ergonomic design
- lumbar support
- tilt tension with lock mechanism



VC8017P-H

- ergonomic design
- lumbar support
- adjustable head support
- tilt tension with lock mechanism





VC8018P

-Tilt tension with lock mechanism



VC8018M

-Tilt tension with lock mechanism



VC8007P

- lumbar support
- tilt tension with lock mechanism

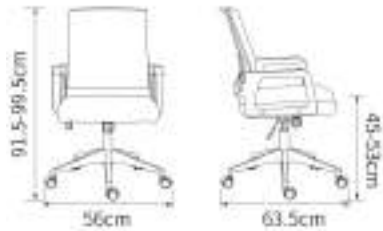

VC8007M

- lumbar support
- tilt tension with lock mechanism



VC8007A

- lumbar support
- bent steel base





VC8007P

- lumbar support
- head support
- tilt tension with lock mechanism



VC8007M

- lumbar support
- head support
- tilt tension with lock mechanism





VC8001P

- lumbar support
- tilt tension with lock mechanism



VC8001M

- lumbar support
- tilt tension with lock mechanism



VC8001A

- lumbar support
- bent steel base





VC8003P

- lumbar support
- tilt tension with lock mechanism



VC8003M

- lumbar support
- tilt tension with lock mechanism



VC8003A

- lumbar support
- bent steel base





VC8009P

- lumbar support
- tilt tension with lock mechanism



VC8009M

- lumbar support
- tilt tension with lock mechanism





VC8905P

- Lumbar support
- Tilt tension with lock mechanism



VC8905P

- Lumbar support
- Tilt tension with lock mechanism



VC1803O

Size: 62*60*78-88cm

SH: 43-53cm



VC1804O

Size: 60*60*75-85cm

SH: 42-52cm



VC1804O(FB)

Size: 60*60*76-86cm

SH: 42-52cm



VC18010

Size: 60*60*77-87cm

SH: 41-51cm



VC18020

Size: 60*60*76-86cm

SH: 41-51cm



VC18010(FB)

Size: 60*60*78-88cm

SH: 41-51cm



VC18020(FB)

Size: 60*60*77-87cm

SH: 41-51cm



PY-05



PY-05



PY-05

THE OPERATION OF TEA TABLE



PY-05



PY-13



PY-13



PY-13



PY-13





PY-07



PY-07



PY-07-2

FURNITURE
FASHION LIFESTYLE

Pursuit of excellence, visual experience, graceful contours and details, life here in the perfect presentation of the classic that can touch the timeless classic, classic aesthetic with the heart and noble of the ordinary.



PY-07





PY-12



PY-12



PY-12



PY-12



PY-12



PY-12



PY-01

PY-06

*In this noisy busy cities
always adhere to the
oneself, favorite latte, love
Blues, with the sound in the
steely flowing notes,
stretch posture in the
belong to my world.*



PY-01-2



PY-06

PY-06



WY-07



WY-07



WY-07-2



WY-07



WY-07-2



WY-07-2



WY-09-



WY-02



WY-09



WY-09



WY-09-2



WY-02-2



WY-02-2



WY-12



WY-12



WY-12



WY-12-2





WY-3



WY-31



WY-29



WY-29



WY-29





WY-27



WY-27



WY-27-2



WY-27





WY-13

WY-13



FURNITURE

FASHION LIFESTYLE

Pursuit of excellence, visual experience, graceful contours and details, life here in the perfect presentation of the classic that can touch the timeless classic, classic aesthetic with the heart and noble of the ordinary.



WY-19

WY-19

WY-19



WY-19-2



WY-19



WY-20



WY-26



WY-26



WY-26



WY-26



WY-26



WY-20



WY-08i



WY-08



WY-08



WY-08-2





WY-21



FURNITURE
FASHION LIFESTYLE

Pursuit of excellence, visual experience, grateful contours and details, life here is the perfect presentation of the classic that can touch the timeless classic, classic aesthetic with the heart and noble of the outlines.

In this noisy busy cities
always adhere to the
oneself, favorite little love
blue, with the sound is the
slowly flowing notes,
stretch posture in the
belong to my world.



GWY-21



GWY-21





WY-03



E0-YM



WY-03



WY-03



WY-03-2



A1118



A1115



A1129



A180



8068A



8828A



B820A



B252



B2120



A1166



B2120-3



A1163



A1163-3



B2217



8655A



612-3



B2112-1



627-3



B2217-3



631



B07-1



B2106-3



B2103-3



8580



B16-1



8680-3



C395-3



667-3



115



117



658



B258



A1119



370



370-2



A1137



B2220



B2220-2

Quality office life
DIFFERENT
ANGLES
SAME
WONDERFUL



A1101



B2101-2



308-2



308-2



206-3



308



308



2102-3



363-1



The best partner of the modern office

It integrates creativity, science
and beauty allowing you sit
with pleasure.



2227



2227





370



370



209I



209-1



WY-01



WY-01



391



391-2

GFY2201A

Leather: high-quality silicone leather or Microfiber leather, imported Semi-aniline Leather or Pure aniline Leather
Sponge: High-quality high resilience sponge,
Handrail Sponge: 40 density high resilience sponge
Wood planks: 28MM thick inner and outer bent boards
Armrest: Contact surface leather
Chassis: Luxury multifunctional aluminum alloy chasis
Air rod: BIFMA Certified brand
Chair foot: All-resin inverted mold president five-star foot, with log color decorative cover, refined by three layers of powder spraying process
Chair Wheel: BIFMA Certified silent wheel



Emma Brown





GFY2201A

Leather: high-quality silicone leather or Microfiber leather, imported

Semi-aniline Leather or Pure aniline Leather

Sponge: High-quality high resilience sponge,

Handrail Sponge: 40 density high resilience sponge

Wood planks: 28MM thick inner and outer bent boards

Armrest: Contact surface leather

Chassis: Luxury multifunctional aluminum alloy chasis

Air rod: BIFMA Certified brand

Chair foot: All-resin inverted mold president five-star foot, with log color decorative cover, refined by three layers of powder spraying process

Chair Wheel: BIFMA Certified silent wheel



Grey

Bordeaux Red



GFY2203A

Leather: high-quality silicone leather or Microfiber leather, imported Semi-aniline Leather or Pure aniline Leather
 Sponge: High-quality high resilience sponge,
 Handrail Sponge: 40 density high resilience sponge
 Wood planks: 28MM thick inner and outer bent boards
 Armrest: Contact surface leather
 Chassis: Luxury multifunctional aluminum alloy chasis
 Air rod: BIFMA Certified brand
 Chair foot: All-resin inverted mold president five-star foot, with log color decorative cover, refined by three layers of powder spraying process
 Chair Wheel: BIFMA Certified silent wheel



Ferrari Red



Classic Black



White+Blue



GFY2205A

Leather: high-quality silicone leather or Microfiber leather, imported Semi-aniline Leather or Pure aniline Leather
Sponge: High-quality high resilience sponge,
Handrail Sponge: 40 density high resilience sponge
Wood planks: 28MM thick inner and outer bent boards
Armrest: Contact surface leather
Chassis: Luxury multifunctional aluminum alloy chasis
Air rod: BIFMA Certified brand
Chair foot: All-resin inverted mold president five-star foot, with log color decorative cover, refined by three layers of powder spraying process
Chair Wheel: BIFMA Certified silent wheel



Bordeaux Red



Classic Black

GFY2206A

Leather: high-quality silicone leather or Microfiber leather, imported
Semi-aniline Leather or Pure aniline Leather
Sponge: High-quality high resilience sponge,
Handrail Sponge: 40 density high resilience sponge
Wood planks: 28MM thick inner and outer bent boards
Armrest: Contact surface leather
Chassis: Luxury multifunctional aluminum alloy chasis
Air rod: BIFMA Certified brand
Chair foot: All-resin inverted mold president five-star foot, with log color
decorative cover, refined by three layers of powder spraying process
Chair Wheel: BIFMA Certified silent wheel



White+Blue



Blue

GFY2207A

Leather: high-quality silicone leather or Microfiber leather, imported Semi-aniline Leather or Pure aniline Leather
Sponge: High-quality high resilience sponge,
Handrail Sponge: 40 density high resilience sponge
Wood planks: 28MM thick inner and outer bent boards
Armrest: Contact surface leather



White+Morandi



Classic Black



Chassis: Luxury multifunctional aluminum alloy chasis
Air rod: BIFMA Certified brand
Chair foot: All-resin inverted mold president five-star foot, with log color decorative cover, refined by three layers of powder spraying process
Chair Wheel: BIFMA Certified silent wheel

GFY2208A

Leather: high-quality silicone leather or Microfiber leather, imported

Semi-aniline Leather or Pure aniline Leather

Sponge: High-quality high resilience sponge,

Handrail Sponge: 40 density high resilience sponge

Wood planks: 28MM thick inner and outer bent boards

Armrest: Contact surface leather



Grey



Bordeaux Red



Chassis: Luxury multifunctional aluminum alloy chasis

Air rod: BIFMA Certified brand

Chair foot: All-resin inverted mold president five-star foot, with log color decorative cover, refined by three layers of powder spraying process

Chair Wheel: BIFMA Certified silent wheel

GFY2209A

Leather: high-quality silicone leather or Microfiber leather, imported Semi-aniline Leather or Pure aniline Leather

Sponge: High-quality high resilience sponge,

Handrail Sponge: 40 density high resilience sponge

Wood planks: 28MM thick inner and outer bent boards

Armrest: Contact surface leather

Chassis: Luxury multifunctional aluminum alloy chasis

Air rod: BIFMA Certified brand

Chair foot: All-resin inverted mold president five-star foot, with log color decorative cover, refined by three layers of powder spraying process

Chair Wheel: BIFMA Certified silent wheel



GFY2210A

Leather: high-quality silicone leather or Microfiber leather, imported Semi-aniline Leather or Pure aniline Leather
Sponge: High-quality high resilience sponge,
Handrail Sponge: 40 density high resilience sponge
Wood planks: 28MM thick inner and outer bent boards
Armrest: Contact surface leather
Chassis: Luxury multifunctional aluminum alloy chasis
Air rod: BIFMA Certified brand
Chair foot: All-resin inverted mold president five-star foot, with log color decorative cover, refined by three layers of powder spraying process
Chair Wheel: BIFMA Certified silent wheel



Grey



Emerald



Brown



GFY1101A

Leather: high-quality silicone leather or Microfiber leather, imported
Semi-aniline Leather or Pure aniline Leather
Sponge: High-quality high resilience sponge,
Handrail Sponge: 40 density high resilience sponge
Wood planks: 28MM thick inner and outer bent boards

Armrest: Contact surface leather
Chassis: Luxury multi-function chassis
Air rod: BIFMA Certified brand
Legs: Finely polished electroplated legs
Chair Wheel: BIFMA Certified silent wheel



Iron Grey



GFY1102A

Leather: high-quality silicone leather or Microfiber leather, imported
Semi-aniline Leather or Pure aniline Leather
Sponge: High-quality high resilience sponge,
Handrail Sponge: 40 density high resilience sponge
Wood planks: 28MM thick inner and outer bent boards

Armrest: Contact surface leather
Chassis: Luxury multi-function chassis
Air rod: BIFMA Certified brand
Legs: Finely polished electroplated legs
Chair Wheel: BIFMA Certified silent wheel



Sky Grey



GFY1103A

Leather: high-quality silicone leather or Microfiber leather, imported
Semi-aniline Leather or Pure aniline Leather
Sponge: High-quality high resilience sponge,
Handrail Sponge: 40 density high resilience sponge
Wood planks: 28MM thick inner and outer bent boards

Armrest: Contact surface leather
Chassis: Luxury multi-function chassis
Air rod: BIFMA Certified brand
Legs: Finely polished aluminium legs
Chair Wheel: BIFMA Certified silent wheel



Classic Black



GFY1104A

Leather: high-quality silicone leather or Microfiber leather, imported
Semi-aniline Leather or Pure aniline Leather
Sponge: High-quality high resilience sponge,
Handrail Sponge: 40 density high resilience sponge
Wood planks: 28MM thick inner and outer bent boards



Grey



Armrest: Contact surface leather
Chassis: Luxury multi-function chassis
Air rod: BIFMA Certified brand
Legs: Finely polished aluminium legs
Chair Wheel: BIFMA Certified silent wheel

Brown

GFY1203A

Leather: high-quality silicone leather or Microfiber leather, imported
Semi-aniline Leather or Pure aniline Leather
Sponge: High-quality high resilience sponge,
Handrail Sponge: 40 density high resilience sponge
Wood planks: 28MM thick inner and outer bent boards
Armrest: Contact surface leather
Chassis: Luxury multi-purpose aircraft chassis
Air rod: BIFMA Certified brand
Legs: Finely polished legs
Chair Wheel: BIFMA Certified silent wheel



Grey





GFY1203B

Leather: high-quality silicone leather or Microfiber leather, imported
 Semi-aniline Leather or Pure aniline Leather
 Sponge: High-quality high resilience sponge,
 Handrail Sponge: 40 density high resilience sponge
 Wood planks: 28MM thick inner and outer bent boards
 Armrest: Contact surface leather
 Chassis: Luxury multi-purpose aircraft chassis
 Air rod: BIFMA Certified brand
 Legs: Finely polished aluminium legs
 Chair Wheel: BIFMA Certified silent wheel



Grey

GFY1204A

Leather: high-quality silicone leather or Microfiber leather, imported

Semi-aniline Leather or Pure aniline Leather

Sponge: High-quality high resilience sponge,

Handrail Sponge: 40 density high resilience sponge

Wood planks: 28MM thick inner and outer bent boards



Grey+Blue



Armrest: Contact surface leather

Chassis: Luxury multi-function chassis

Air rod: BIFMA Certified brand

Legs: Finely polished aluminium legs

Chair Wheel: BIFMA Certified silent wheel

GFY1207(A/B)

Leather: Premium PU or ImportBlack Semi-aniline Leather

Color Semi-aniline Leather

Sponge: High-quality high resilience sponge,

Handrail sponge: high-density raw cotton

Wood planks: 28MM thick inner and outer bent boards



Beige+Grey

(A)



Beige+Grey

(B)



Armrest: Contact surface leather
Chassis: Multifunctional aircraft chassis
Air rod: BIFMA Certified brand
Legs: Finely polished aluminium legs
Chair Wheel: BIFMA Certified silent wheel

GFY1209A

Leather: Premium PU or ImportBlack Semi-aniline Leather
 Color Semi-aniline Leather
 Sponge: High-quality high resilience sponge,
 Handrail sponge: high-density raw cotton
 Wood planks: 28MM thick inner and outer bent boards



Iron Grey



Classic Black



GFY1210A

Leather: Premium PU or ImportBlack Semi-aniline Leather
Color Semi-aniline Leather
Sponge: High-quality high resilience sponge,
Handrail sponge: high-density raw cotton
Wood planks: 28MM thick inner and outer bent boards



Light Grey+Dark Grey



Armrest: Contact surface leather
Chassis: Multifunctional aircraft chassis
Air rod: BIFMA Certified brand
Legs: Finely polished stainless steel electroplated legs
Chair Wheel: BIFMA Certified silent wheel



GFY1211A

Leather: high-quality silicone leather or Microfiber leather, imported Semi-aniline Leather or Pure aniline Leather
Sponge: High-quality high resilience sponge,
Handrail Sponge: 40 density high resilience sponge
Wood planks: 28MM thick inner and outer bent boards



Light Grey+Dark Grey



Brown+Grey



Armrest: Contact surface leather
Chassis: Luxury multifunctional aluminum alloy chasis
Air rod: BIFMA Certified brand
Legs: Finely polished aluminium legs
Chair Wheel: BIFMA Certified silent wheel



GFY1212A

Leather: high-quality silicone leather or Microfiber leather, imported
Semi-aniline Leather or Pure aniline Leather
Sponge: High-quality high resilience sponge,
Handrail Sponge: 40 density high resilience sponge
Wood planks: 28MM thick inner and outer bent boards



Dark Grey+Coffee



Light Grey+Dark Grey



Armrest: Contact surface leather
Chassis: Luxury multi-function chassis
Air rod: BIFMA Certified brand
Legs: Finely polished aluminium legs
Chair Wheel: BIFMA Certified silent wheel



GFY1213A

Leather: high-quality silicone leather or Microfiber leather, imported Semi-aniline Leather or Pure aniline Leather
Sponge: High-quality high resilience sponge,
Handrail Sponge: 40 density high resilience sponge
Wood planks: 28MM thick inner and outer bent boards



Light Grey+Dark Grey



Armrest: Contact surface leather
Chassis: Luxury multi-function chassis
Air rod: BIFMA Certified brand
Legs: Finely polished aluminium legs
Chair Wheel: BIFMA Certified silent wheel



GFY1213C

Leather: Premium PU or ImportBlack Semi-aniline Leather或Color Semi-aniline Leather

Sponge: High-quality high resilience sponge,
Handrail sponge: high-density raw cotton



Light Grey+Dark Grey



Wood planks: 28MM thick inner and outer bent boards
Armrest: Contact surface leather
Air rod: BIFMA Certified brand
I-beam: 2.0MM set of 18MM electroplated tripod



GFY1219A

Leather: high-quality silicone leather or Microfiber leather, imported
Semi-aniline Leather or Pure aniline Leather
Sponge: High-quality high resilience sponge,
Handrail Sponge: 40 density high resilience sponge
Wood planks: 28MM thick inner and outer bent boards

Armrest: Contact surface leather
Chassis: Luxury multi-function chassis
Air rod: BIFMA Certified brand
Legs: Finely polished aluminium legs
Chair Wheel: BIFMA Certified silent wheel



Light Grey+D398Grey



GFY1220A

Leather: high-quality silicone leather or Microfiber leather, imported
Semi-aniline Leather or Pure aniline Leather
Sponge: High-quality high resilience sponge,
Handrail Sponge: 40 density high resilience sponge
Wood planks: 28MM thick inner and outer bent boards

Armrest: Contact surface leather
Chassis: Luxury multi-function chassis
Air rod: BIFMA Certified brand
Legs: Finely polished aluminium legs
Chair Wheel: BIFMA Certified silent wheel



Berlin Blue



GFY1221A

Leather: high-quality silicone leather or Microfiber leather, imported
Semi-aniline Leather or Pure aniline Leather
Sponge: High-quality high resilience sponge,
Handrail Sponge: 40 density high resilience sponge
Wood planks: 28MM thick inner and outer bent boards

Armrest: Contact surface leather
Chassis: Luxury multi-function chassis
Air rod: BIFMA Certified brand
Legs: Finely polished aluminium legs
Chair Wheel: BIFMA Certified silent wheel



Grey+Coffee



Khaki

GFY1222A

Leather: Premium PU or ImportBlack Semi-aniline Leather或Color Semi-aniline Leather

Sponge: High-quality high resilience sponge,

Handrail sponge: high-density raw cotton

Wood planks: 28MM thick inner and outer bent boards

Armrest: Contact surface leather

Chassis: Luxury multi-function chassis

Air rod: BIFMA Certified brand

Legs: Finely polished aluminium legs

Chair Wheel: BIFMA Certified silent wheel



Grey+Khaki



GFY1223A

Leather: Premium PU or ImportBlack Semi-aniline Leather或Color Semi-aniline Leather
Sponge: High-quality high resilience sponge,
Handrail sponge: high-density raw cotton
Wood planks: 28MM thick inner and outer bent boards

Armrest: Contact surface leather
Chassis: Luxury multi-function chassis
Air rod: BIFMA Certified brand
Legs: Finely polished aluminium legs
Chair Wheel: BIFMA Certified silent wheel



Khaki+Grey



GFY2202A

Leather: high-quality silicone leather or Microfiber leather, imported
 Semi-aniline Leather or Pure aniline Leather
 Sponge: High-quality high resilience sponge,
 Handrail Sponge: 40 density high resilience sponge
 Wood planks: 28MM thick inner and outer bent boards



Grey+Blue



Khaki+Light Coffee



Orange+Blue



Beige Grey+Blue



Armrest: Contact surface leather
 Chassis: Luxury multifunctional aluminum alloy chasis
 Air rod: BIFMA Certified brand
 Legs: Finely polished aluminium legs
 Chair Wheel: BIFMA Certified silent wheel



Q202

- 1. 60PU nylon wheel
- 2. 340 Pass test seat foot
- 3. SGS certification three-level air rod
- 4. Three-position locking inline chassis
- 5. High-density high-resilience stereotyped sponge
- 6. PA Fixed armrest support with PP armrest cover
- 7. Nylon plus glass fiber chair back

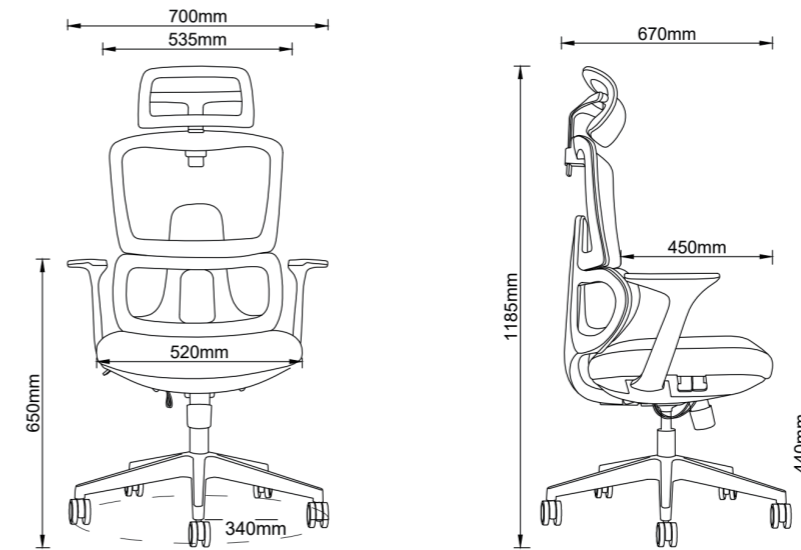

GFY2702B

Customized



GFY2702B-1

- 1) White middle class back frame;
- 2) Nylon back frame with fixed waist back; High rebound mesh;
- 3) No. 55 high-density sponge cushion;
- 4) Nylon split independent handrail;
- 5) Lock the butterfly chassis in situ;
- 6) Black electrophoresis imported three-stage lifting pole;
- 7) 320MM nylon feet;
- 8) 55# silent flat castors;



GFY2702C

- 1) White middle class back frame;
- 2) Nylon back frame with fixed waist back; High rebound mesh;
- 3) No. 55 high-density sponge cushion;
- 4) Bow frame with PU handrail surface;
- 5) The bow frame is sprayed by pickling the surface in white color;



GFY-2703B

- 1) Black middle class back frame;
- 2) Nylon back frame with fixed waist back; High rebound mesh;
- 3) No. 55 high-density sponge cushion;
- 4) Nylon conjoined handrail;
- 5) Lock the butterfly chassis in situ;
- 6) Black electrophoresis imported three-stage lifting pole;
- 7) 320MM nylon feet;
- 8) 55# silent flat castors;



GFY-2703C

- 1) Black middle class back frame;
- 2) Nylon back frame with fixed waist back; High rebound mesh;
- 3) No. 55 high-density sponge cushion;
- 4) Nylon conjoined handrail;
- 5) The bow frame is sprayed with black through the pickling surface;



GFY2706A

- 1) Available lift and lower the rotating headrest;
- 2) Nylon back frame with independent two-segment top waist design; Distribution of imported mesh cloth;
- 3) High-density sponge cushion with seat shell;
- 4) 3D handrail with PU handrail surface;
- 5) The multi-functional chassis with tail plate in the third gear adopts back steel plate connection;
- 6) Electroplating lifting three-stage air rod;
- 7) 340MM aluminum alloy five-star foot;
- 8) 60mmPU silent castors



6033C

- * Yida dustproof mesh cloth
- * PP+ glass fiber back
- * Shaped sponge
- * Medium class butterfly chassis
- * Passed SGS certification three-level black air pressure rod
- * 320# PA nylon feet
- * ϕ 50 black PA nylon wheels

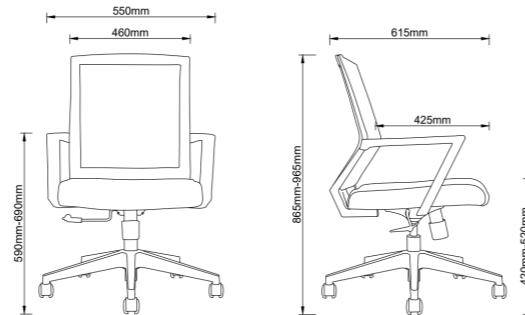

6033D

- * Yida dustproof mesh cloth
- * PP+ glass fiber back
- * Shaped sponge
- * 1*8 thick small square tube electroplated bow frame

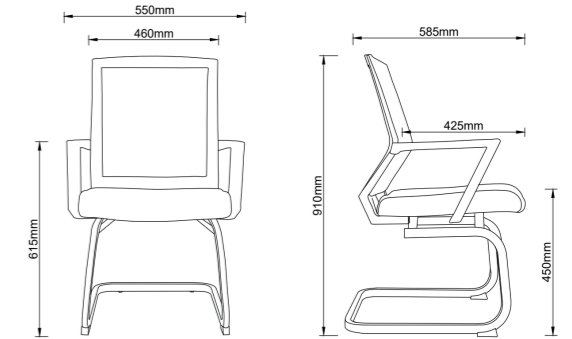

6038B

- * Professional office mesh finish
- * Black PA nylon + glass fiber chair back, sliding lift waist back
- * Lifting armrest with PU surface
- * 12mm thickness seat planks
- * Shaped sponge
- * Synchronous tilt chassis
- * Passed SGS certification three-level black air pressure rod
- * 340# Nylon five-star tall ϕ 60 black PU wheels



6038D

- * Hoau professional office mesh fabric finish
- * Black PA nylon + glass fiber back
- * Lifting armrest with PU surface
- * 12mm thickness seat planks
- * Shaped sponge
- * 1.8 sets of 1.5 thick round tube black lacquered bow frame



6042A

- * Hoau professional office mesh fabric finish
- * Lift adjustment headrest
- * Black PA nylon + glass fiber headrest/chair back, sliding lift waist back
- * 12mm thick seat plate
- * Shaped sponge
- * Lifting armrest with PU surface
- * Four-speed locked luxury chassis
- * Passed SGS certification three-level black air pressure rod
- * 340# Nylon five-star tall ϕ 60 black PU wheels

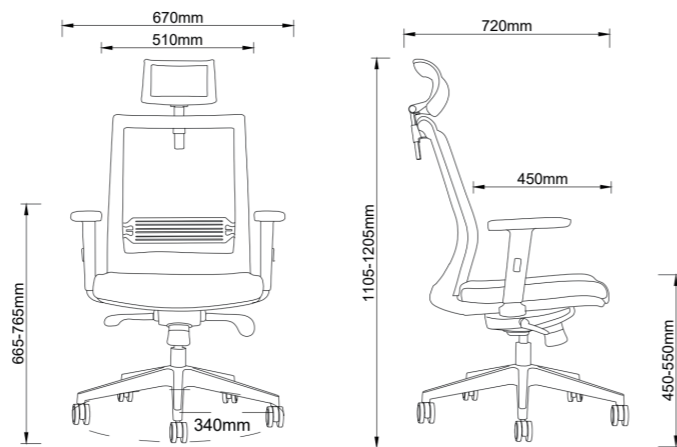

6042B

- * Hoau professional office mesh fabric finish
- * Black PA nylon + glass fiber back, sliding lift waist back
- * 12mm thick seat plate
- * Shaped sponge
- * Lifting armrest with PU surface
- * Medium class butterfly chassis
- * Passed SGS certification three-level black air pressure rod
- * 340# Nylon five-star tall ϕ 60 black PU wheels

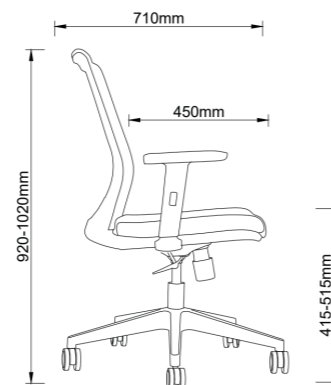
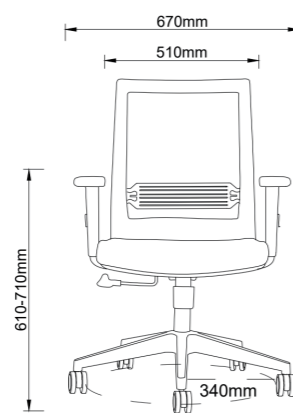

6042D

- * Hoau professional office mesh fabric finish
- * Black PA nylon + glass fiber back
- * PU armrest face
- * 12mm thickness seat plate
- * Shaped sponge, with housing
- * 2.0 thick square tube electroplated large bow frame

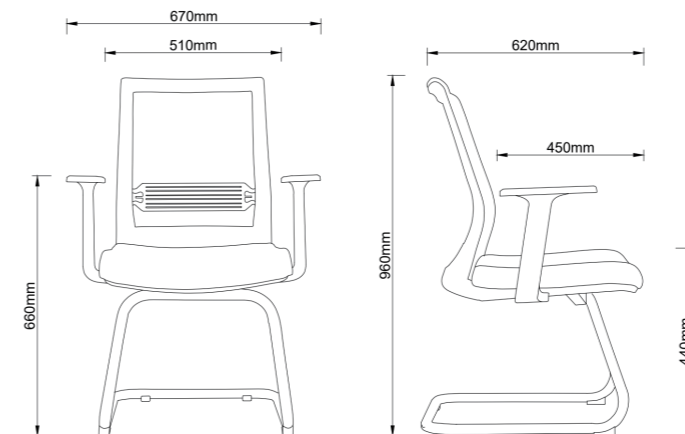

6046A

- * Professional office mesh veneer
- * Lift adjustment headrest
- * Black PP+ glass fiber back, black PA nylon + glass fiber armrest, sliding lift waist back
- * 12mm thick seat plate
- * Shaped sponge
- * Four-speed locked luxury chassis
- * Passed SGS certification three-level black air pressure rod
- * 340# Nylon five-star tall ϕ 60 black PU wheels

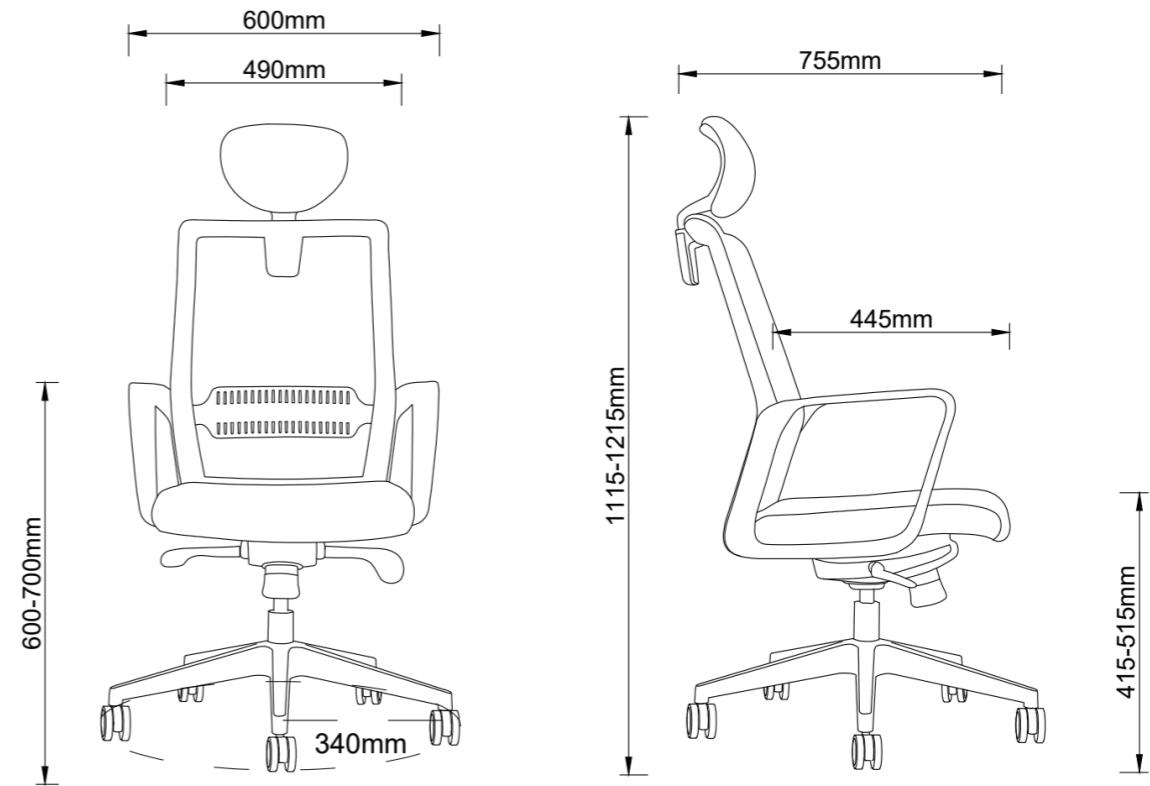

6046B

- * Professional office mesh veneer
- * Black PP+ glass fiber back, black PA nylon + glass fiber armrest, sliding lift waist back
- * 12mm thick seat plate
- * Shaped sponge
- * In-place locked chassis
- * Passed SGS certification three-level black air pressure rod
- * 340# Nylon five-star tall ϕ 60 black PU wheels

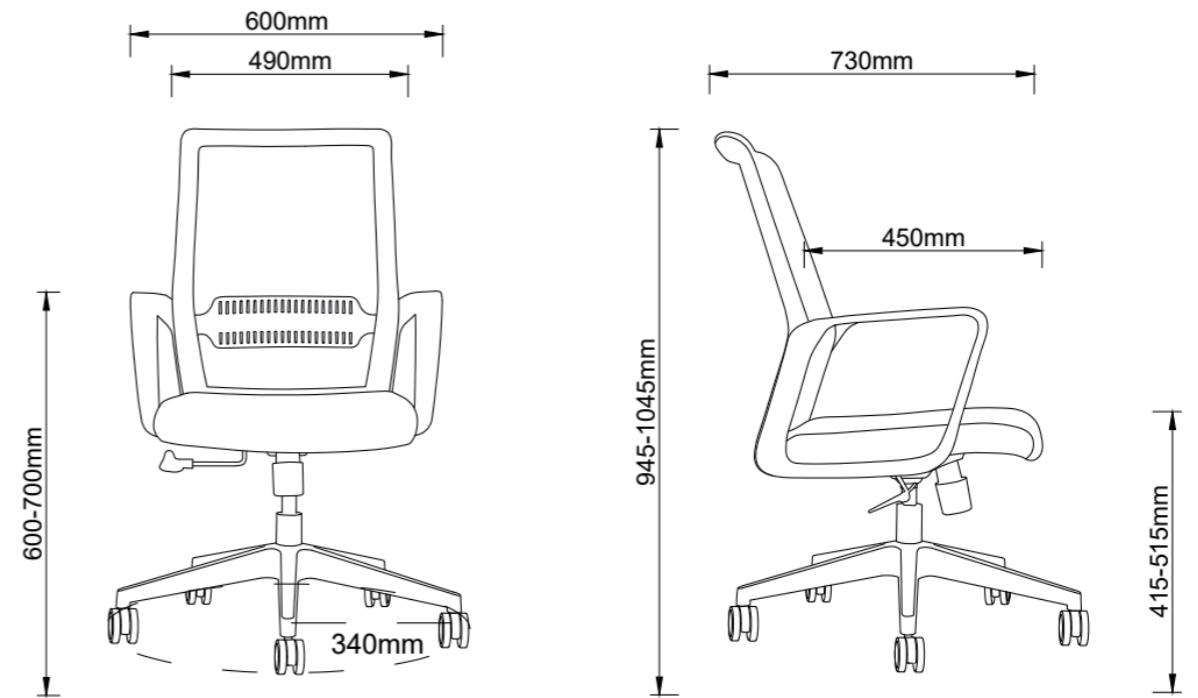

6046D

- * Professional office mesh veneer
- * Black PP+ glass fiber back, black PA nylon + glass fiber armrest, sliding lift waist back
- * 12mm thickness seat plate
- * Shaped sponge
- * 1.8 thick square tube electroplated bow frame

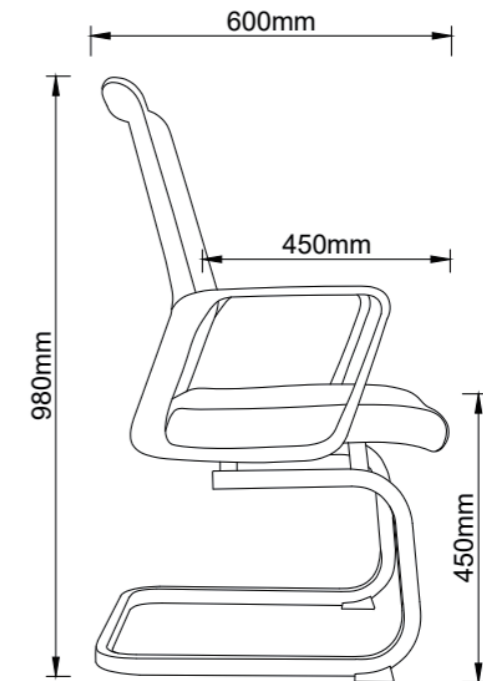
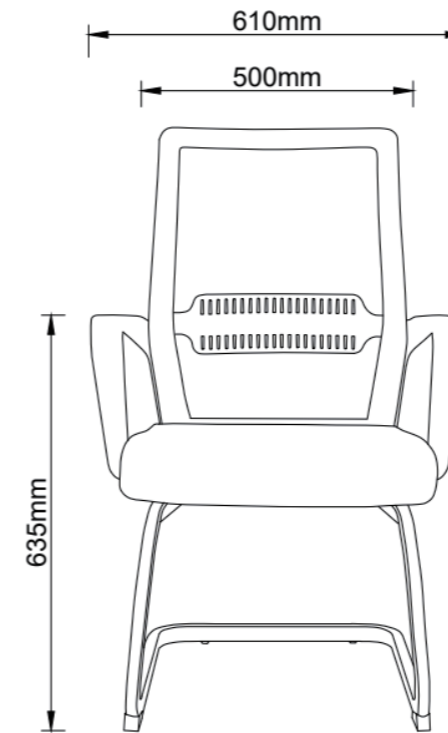

6051



6202C

- * Professional office mesh veneer
- * Black PP+ glass fiber back, black PA nylon + glass fiber armrest
- * 32 High density high resilience native sponge
- * Medium class butterfly chassis
- * Passed SGS certification three-level black air pressure rod
- * 320# PA nylon feet
- * ϕ 50 black PA nylon wheels

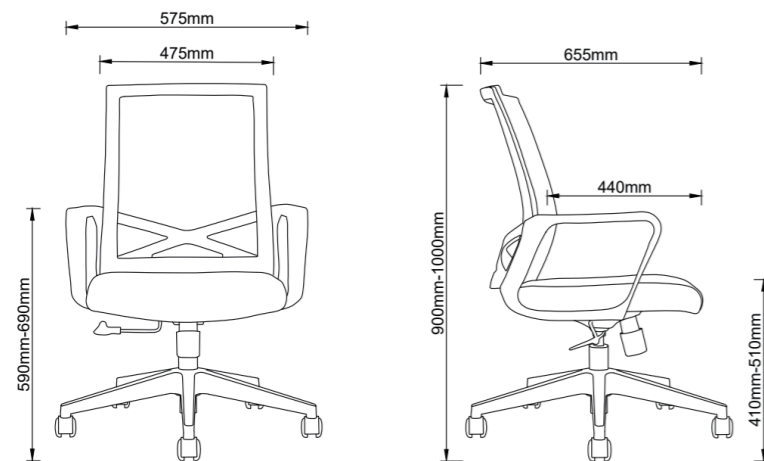

6202D

- * Hoau professional office mesh fabric finish
- * Black PP+ glass fiber back, black PA nylon + glass fiber armrest
- * 32 High density high resilience native sponge
- * 1.5 thickness 25 round tube black lacquered bow frame

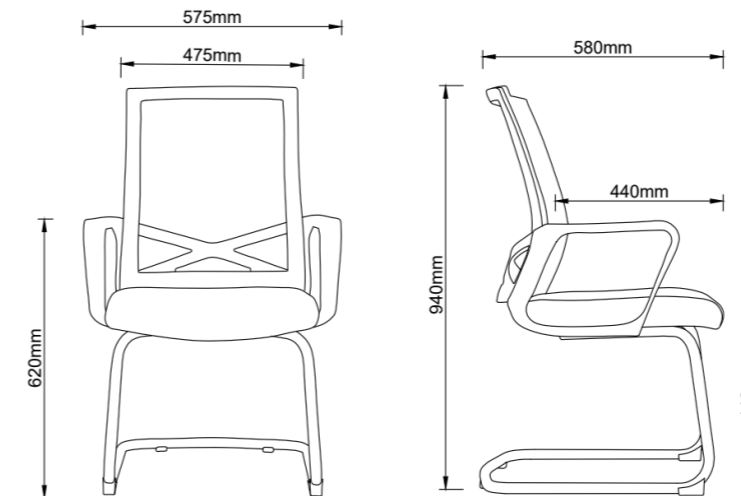

6203C

- * Hoau professional office mesh fabric finish
- * Black PA nylon + glass fiber back
- * PP fixed armrest
- * 32 High density high resilience native sponge
- * Shift pull-back chassis
- * Passed SGS certification three-level black air pressure rod
- * 320# PA nylon feet, ϕ 50 black PA nylon wheels

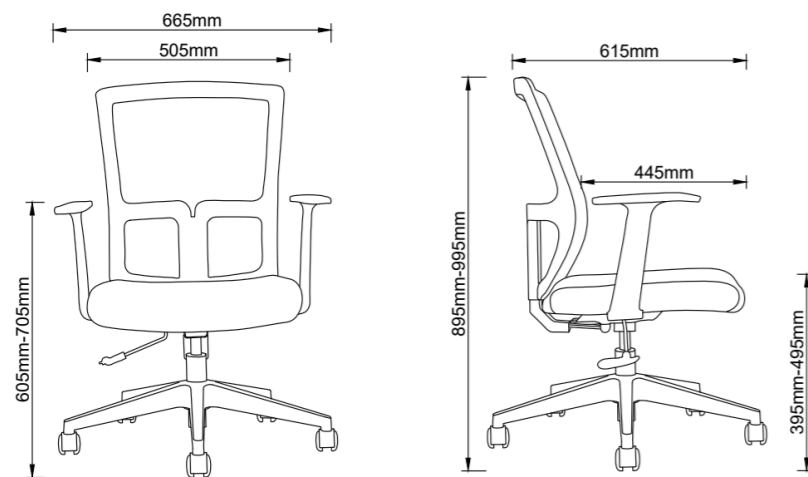

6203D

- * Hoau professional office mesh fabric finish
- * Black PA nylon + glass fiber back
- * PP fixed armrest
- * 32 High density high resilience native sponge
- * 1.5 thickness 25 round tube black lacquered bow frame

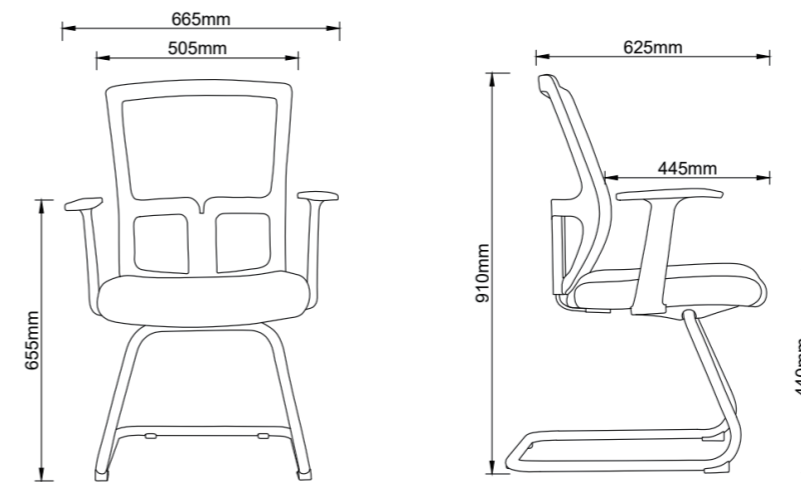

6205C

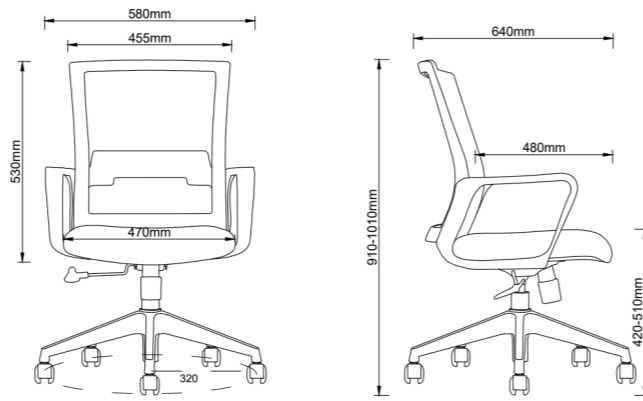

6205D

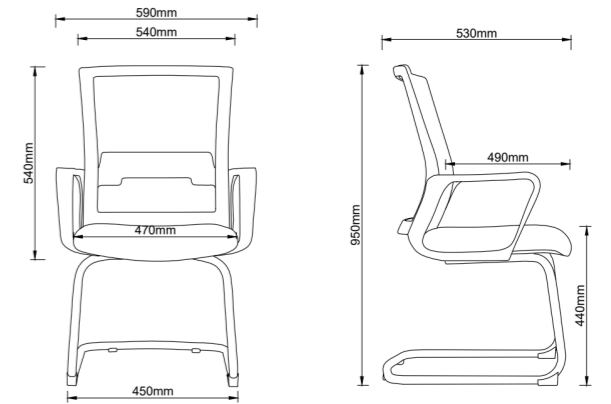

6206A

- * Professional office mesh veneer
- * Black PA nylon + glass fiber chair back/headrest with PU West leather surface / with hanger
- * Lifting armrest with PU surface
- * Shaped sponge
- * Three-position locking and front and rear sliding function chassis
- * Passed SGS certification three-level black air pressure rod
- * 340# Nylon five-star tall ϕ 60 black PU wheels

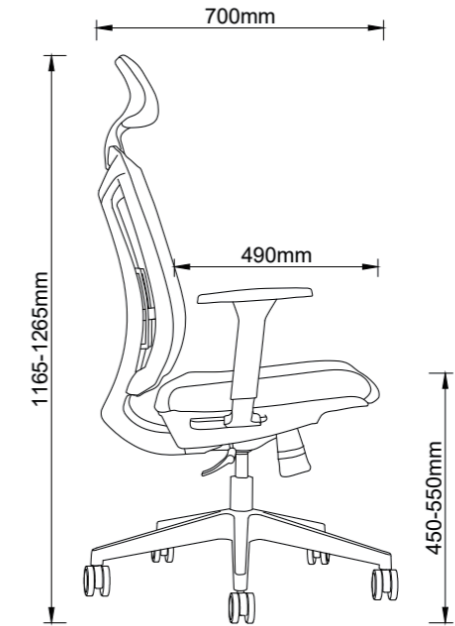
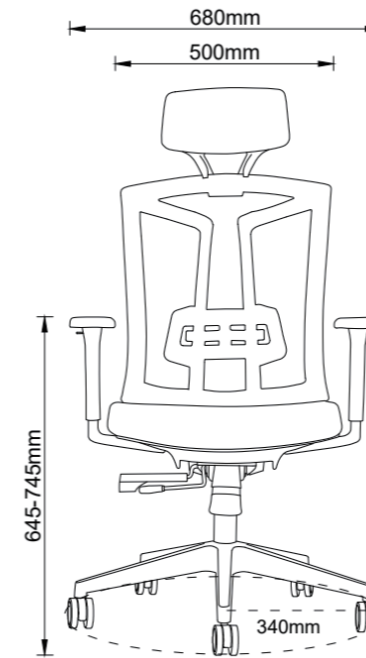

6206B

- * Professional office mesh veneer
- * Black PA nylon + glass fiber back
- * Lifting armrest with PU surface
- * Shaped sponge
- * Three-position locking and front and rear sliding function chassis
- * Passed SGS certification three-level black air pressure rod
- * 340# Nylon five-star tall with ϕ 60 black PU wheel

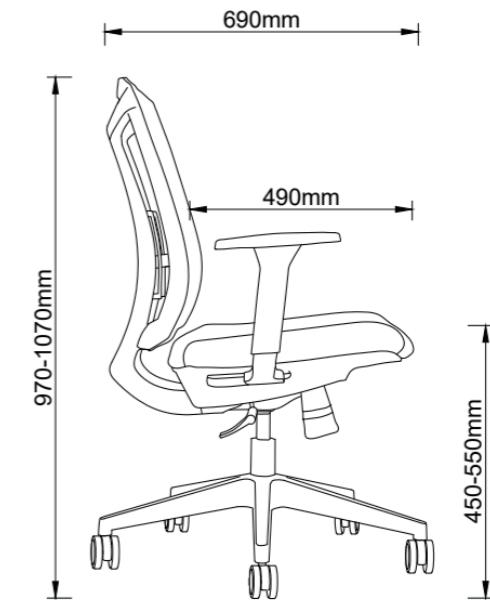
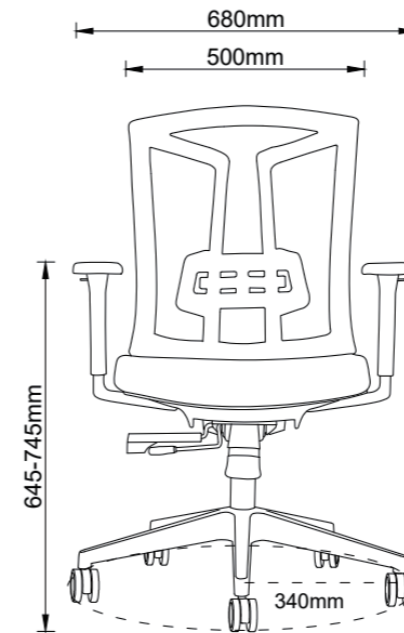

6206D

- * Professional office mesh veneer
- * Nylon plus glass fiber chair back
- * Shaped sponge with base shell
- * PU armrest face
- * 28 round tubes 1.8 sets of 1.5 thickness electroplated bow frame

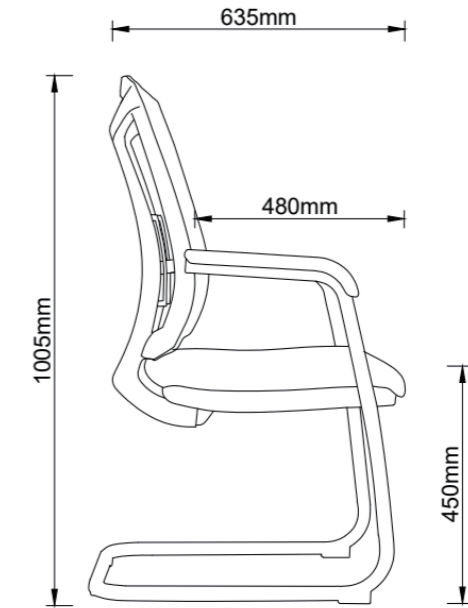
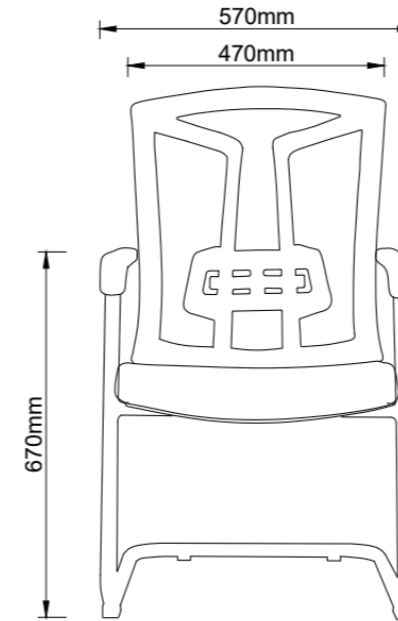

6208A

- * Professional office mesh veneer
- * Black PA nylon + glass fiber chair back/headrest (styling cotton)
- * Lifting armrest with PU surface
- * Shaped sponge
- * Three-position locking and front and rear sliding function chassis
- * Passed SGS certification three-level black air pressure rod
- * 340# Nylon five-star tall ϕ 60 black PU wheels

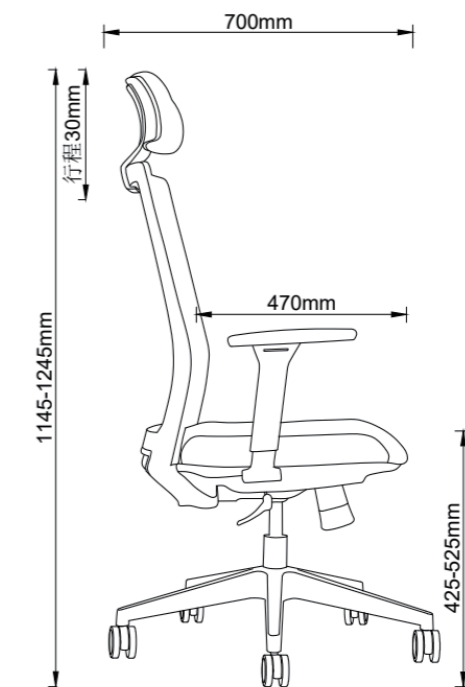
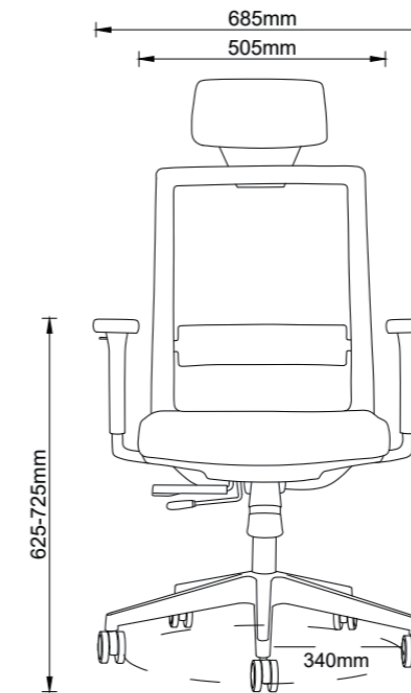

6208B

- * Professional office mesh veneer
- * Black PA nylon + glass fiber back
- * Lifting armrest with PU surface
- * Shaped sponge
- * Three-position locking and front and rear sliding function chassis
- * Passed SGS certification three-level black air pressure rod
- * 340# Nylon five-star tall ϕ 60 black PU wheels

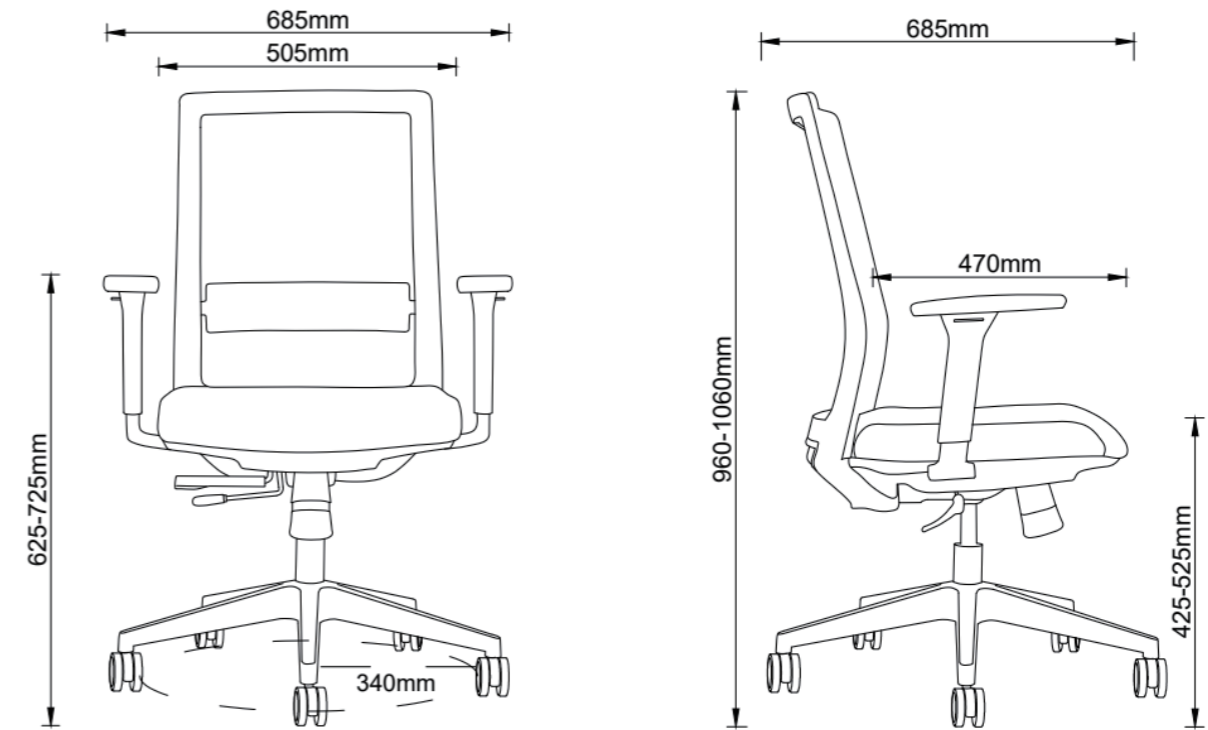

6208D

- * Professional office mesh veneer
- * Black nylon glass fiber chair back
- * Shaped sponge
- * PU armrest face
- * 28 round tubes 1.8 sets of 1.5 thickness electroplated bow frame

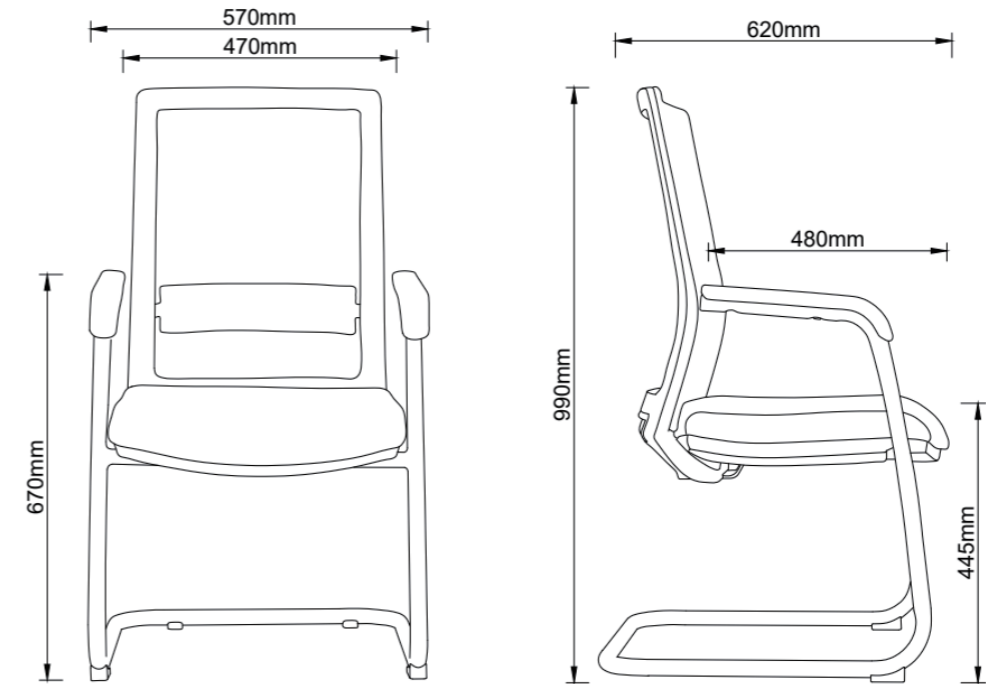

6209A

Customized

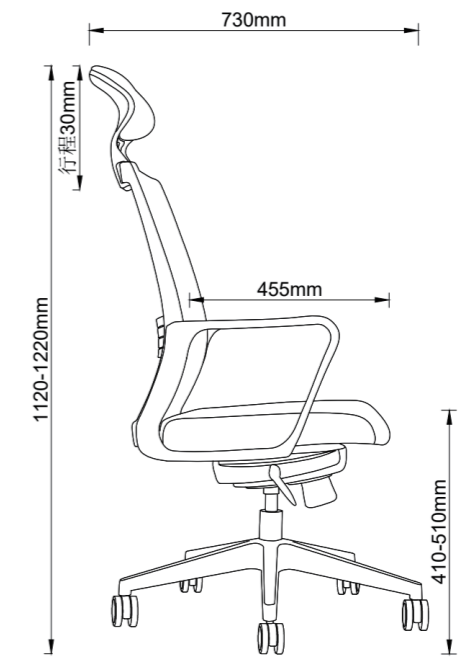
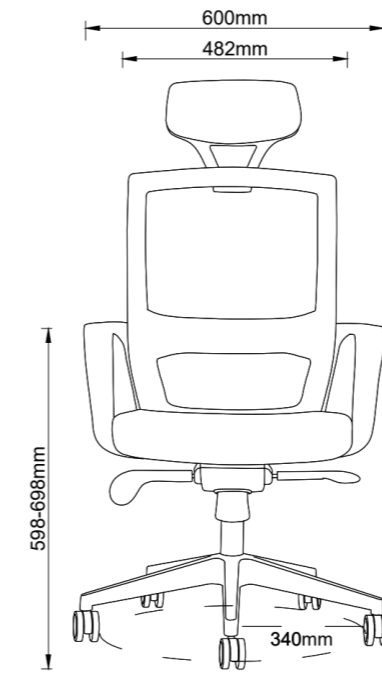

6209B

Customized

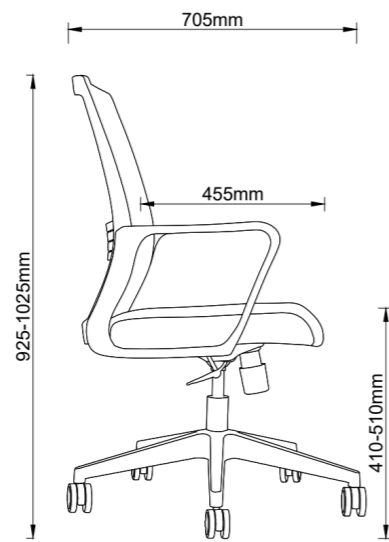
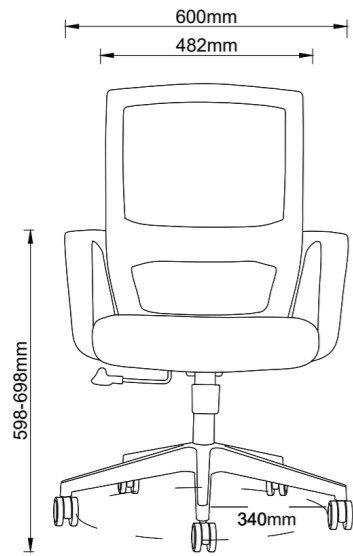

6209D

Customized

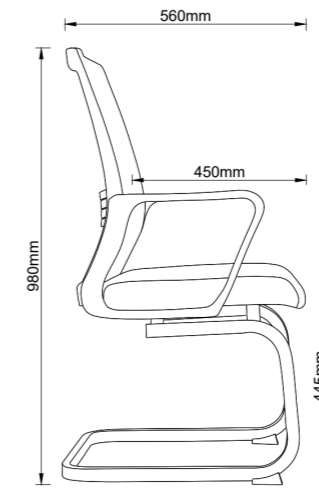
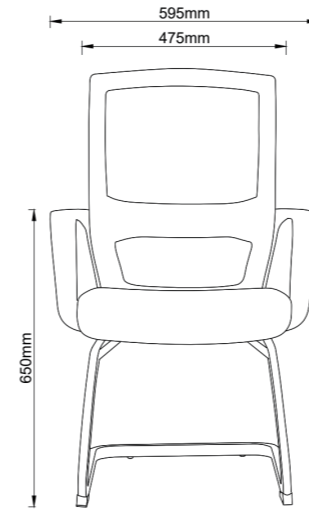

6212A

- * Professional office mesh fabric finish OA series
- * Black PA nylon + glass fiber chair back/headrest (styling cotton)
- * Black lifting armrest with PU surface
- * Shaped sponge with chassis, four-speed locking and front and rear sliding function chassis
- * Passed SGS certification three-level black air pressure rod
- * 340# Nylon five-star tall ϕ 60 black PU wheels



6212B

- * Professional office mesh fabric finish OA series
- * Black PA nylon + glass fiber back
- * Black lifting armrest with PU surface
- * Shaped sponge with chassis, four-speed locking and front and rear sliding function chassis
- * Passed SGS certification three-level black air pressure rod
- * 340# Nylon five-star tall ϕ 60 black PU wheels



6212D

- * Professional office mesh fabric finish OA series
- * Black PA nylon + glass fiber back
- * Shaped sponge
- * PU armrest face
- * 28 round tubes 1.8 sets of 1.5 thickness electroplated bow frame

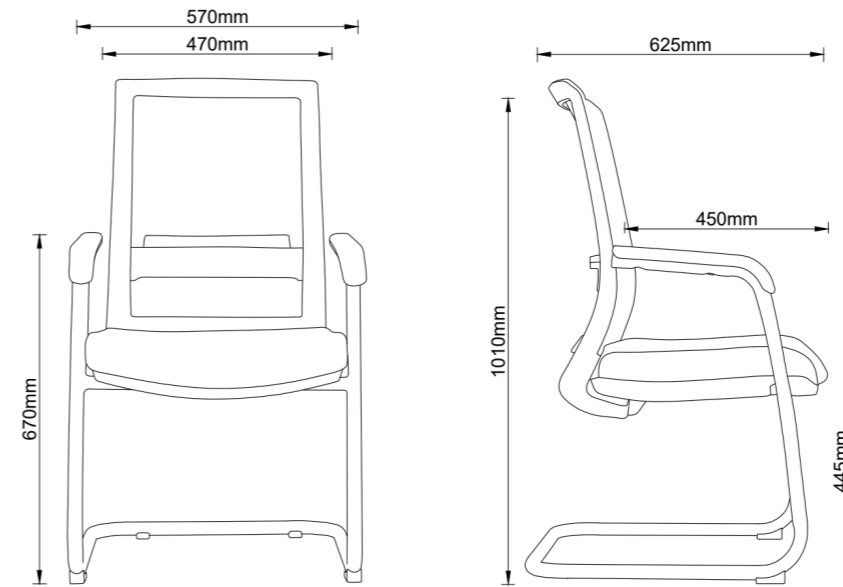

6225A

- *YY12 series special mesh
- *Black PA nylon + glass fiber chair back/headrest, adjustable headrest, waist protection design waist rest
- *3D lifting handrail with PU surface
- * Aluminum alloy connectors
- *Shaped sponge with base shell
- * Luxury load-up chassis with front and back sliding and forward tilt function
- *Passed SGS certification three-level black air pressure rod
- *340# Nylon five-star foot with ϕ 60 black PU wheels

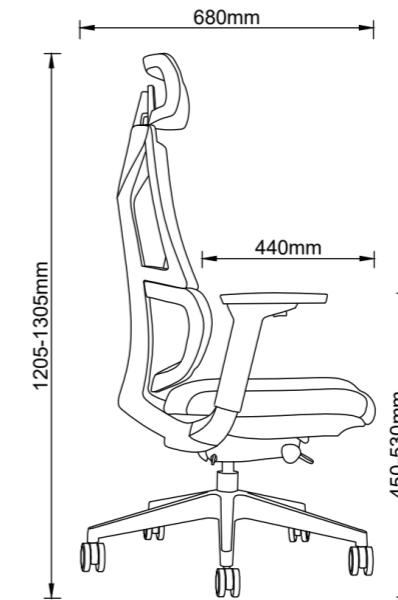
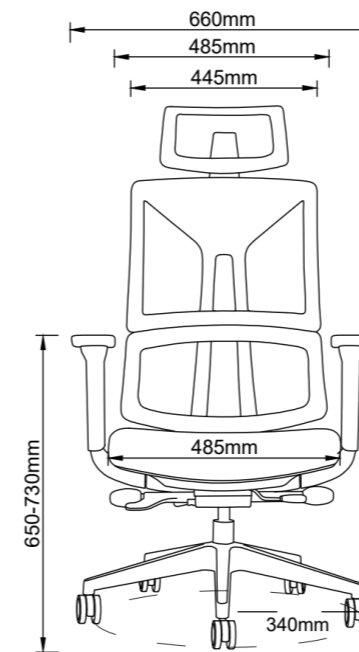

6225B

- *YY12 series mesh
- *Black PA nylon + glass fiber chair back/headrest, waist guard design waist back
- *3D lifting handrail with PU surface
- * Aluminum alloy connectors
- *Shaped sponge with base shell
- * Luxury load-up chassis with front and back sliding and forward tilt function
- *Passed SGS certification three-level black air pressure rod
- *340# Nylon five-star foot with ϕ 60 black PU wheels

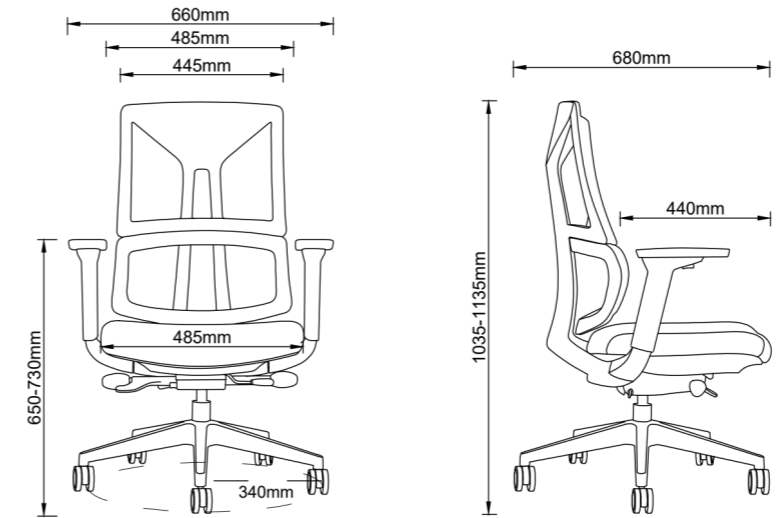

6229B

Customized

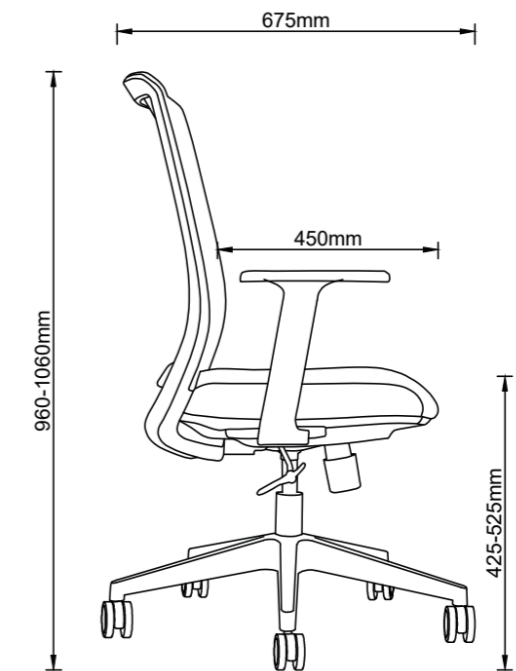
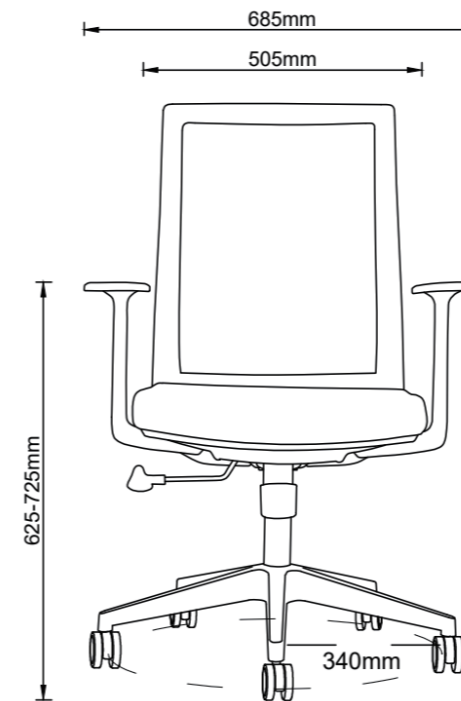

6236A

- * Professional office exclusive mesh
- * Black PA nylon back + PU telescopic lumbar
- * 3D armrests
- * Full network seat + exclusive mesh
- * Three-position locked chassis
- * Passed SGS certification three-level black air pressure rod
- * 350# black nylon feet with ϕ 60 black PU wheels

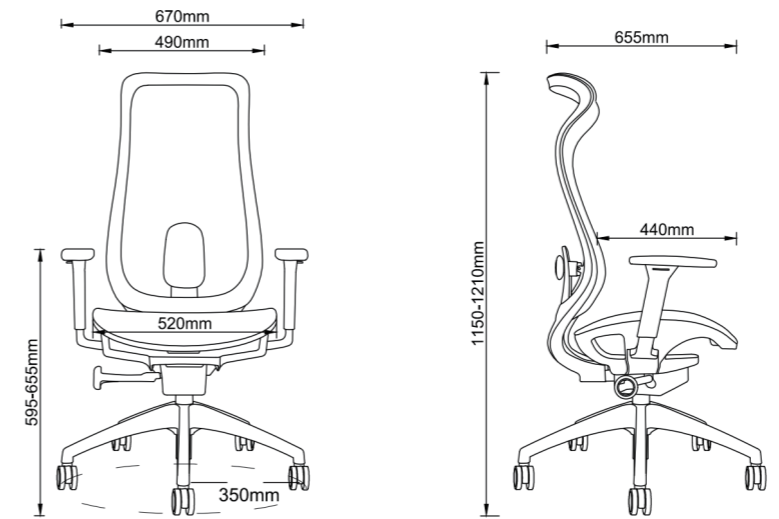

6237A

- * Professional office exclusive mesh
- * Black PA nylon back + PU telescopic lumbar
- * 1D armrests
- * Styling sponge + special net
- * Three-position locked chassis
- * Passed SGS certification three-level black air pressure rod
- * 350# black nylon feet with ϕ 60 black PU wheels

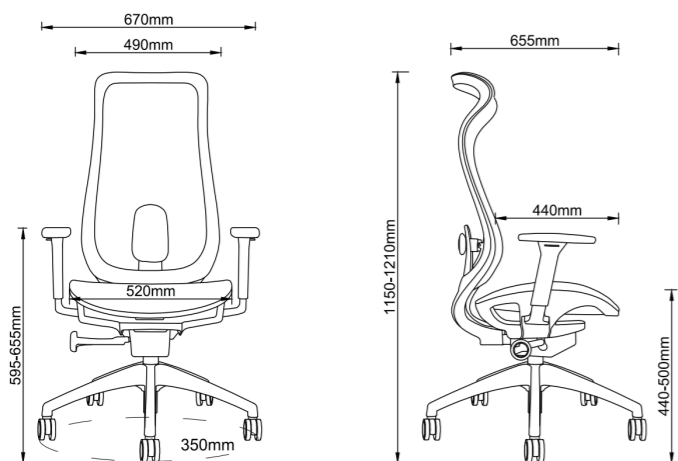

6238A

- *Black PP+ glass fiber headrest/seat backrest with adjustable headrest, adjustable waist rest
- * Professional office mesh veneer
- *6208 fixed armrest
- *12mm thickness seat planks
- * Shaped sponge, single function locking chassis
- *Passed SGS certification three-level black air pressure rod
- *340# black nylon five-star foot, ϕ 60 black PU wheel



6238AHS

- *Grey PP+ glass fiber headrest/chair back, with adjustable headrest, adjustable waist rest
- * Professional office mesh veneer
- *6208 fixed armrest
- *12mm thickness seat planks
- * Shaped sponge, single function locking chassis
- *Passed SGS certification three-level black air pressure rod
- *340# gray nylon five-star foot, ϕ 60 black PU wheels



6238B

- *Black PP+ glass fiber headrest/seat back, adjustable waist back
- * Professional office mesh veneer
- *6208 fixed armrest
- *12mm thickness seat planks
- * Shaped sponge, single function locking chassis
- *Passed SGS certification three-level black air pressure rod
- *340# black nylon five-star foot, ϕ 60 black PU wheel



6238BHS

- *Grey PP+ glass fiber headrest/chair back, with adjustable headrest, adjustable waist rest
- * Professional office mesh veneer
- *6208 fixed armrest
- *12mm thickness seat planks
- * Shaped sponge, single function locking chassis
- *Passed SGS certification three-level black air pressure rod
- *340# gray nylon five-star foot, ϕ 60 black PU wheels



6238D

- *Black PP+ glass fiber headrest/seat back, adjustable waist back
- * Professional office mesh veneer
- *12mm thickness seat planks
- *Shaped sponge, with housing
- *Polyurethane armrest face
- *28 round tubes 1.8 sets of 1.5 thickness electroplated bow frame



6238DHS

- *Gray PP+ glass fiber headrest/seat back, adjustable waist back
- * Professional office mesh veneer
- *12mm thickness seat planks
- *Shaped sponge, with housing
- *Polyurethane armrest face
- *28 round tubes 1.8 sets of 1.5 thickness electroplated bow frame



8896A

- *INTA OA professional office mesh finish
- *Lifting adjustment headrest
- *Black PA nylon glass fiber chair back, armrests
- *12mm thick seat plate
- * Shaped sponge
- * Guowei 3rd gear lock synchronous tilt chassis
- *Passed SGS certification three-level black air pressure rod
- *340# Nylon five-star tall ϕ 60 black PU mute wheels

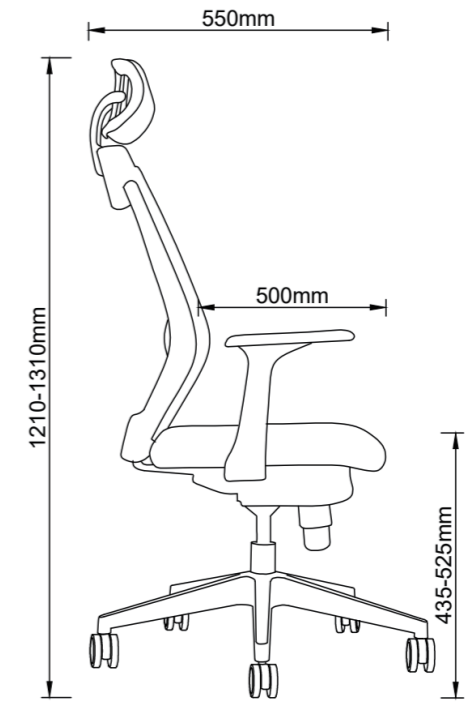
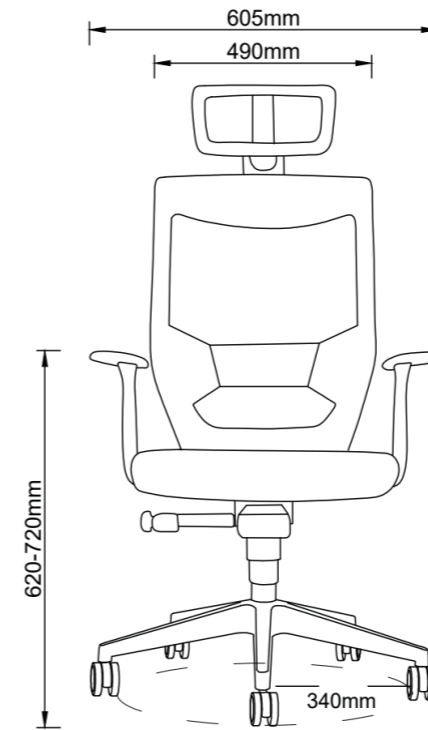

8896B

- * INEDA OA professional office mesh finish
- * Black PA nylon glass fiber chair back, armrests
- * 12mm thick seat plate
- * Shaped sponge
- * Guowei 3rd gear lock synchronous tilt chassis
- * Passed SGS certification three-level black air pressure rod
- * 340# Nylon five-star tall ϕ 60 black PU mute wheels

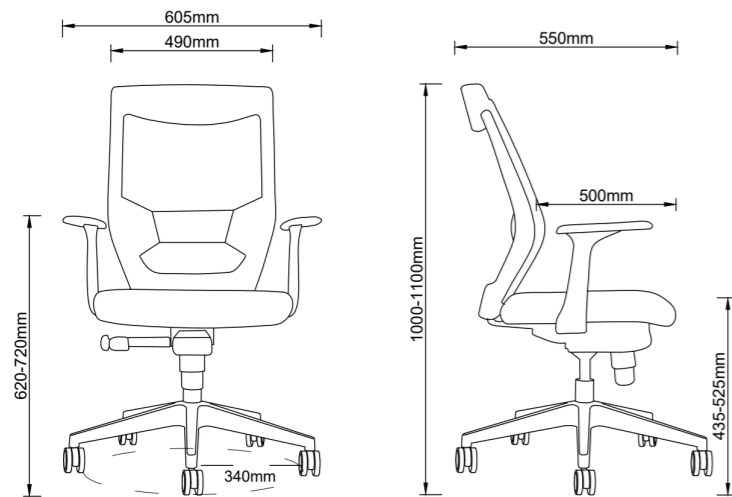

8896D

- * INEDA OA professional office mesh fabric finish
- * PA nylon glass fiber injection molding accessories
- * 12mm thickness seat plate
- * Shaped sponge
- * 2.0 thick round tube electroplated bow frame





ROYAL NOVA



United Arab Emirates

Suite 26C-09, I-Rise Tower, Barsha Heights (Tecom), Hessa St., Dubai

Tel.: +971 4 390 8325 email: info@royalnova.com <http://www.royalnova.com>